

ViSiCAST Deliverable D5-1: Interface Definitions

Project Number:	IST-1999-10500
Project Title:	ViSiCAST Virtual Signing: Capture, Animation, Storage and Transmission
Deliverable Type:	Int (Internal)

Deliverable Number:	D5-1
Contractual Date of Delivery:	December 2000
Actual Date of Delivery:	February 2001 (revision 1: October 2001)
Title of Deliverable:	Interface Definitions
Work-Package contributing to the Deliverable:	WP 5 (Language and Notation)
Nature of the Deliverable:	RE (Report)
Author(s):	Thomas Hanke (ed.) (Please find names of individual authors at the end of each chapter)

Abstract:

This report describes the languages defined to interface between various components which are developed within work-package 5. At a later point of time, these languages will also become visible to other components in other work-packages as well as to users of the authoring environment. Chapter 1 gives an introduction and relates the following chapters to each other. Ch. 2 describes the language chosen to define semantic contents of phrases to be translated into sign language, mainly based on Discourse Representation Theory. Ch. 3 documents the revisions that have been made to HamNoSys, a notation system mainly for manual components of sign languages, in order to meet the requirements of the project. Ch. 4 describes the notation systems defined for non-manual aspects of sign language. Ch. 5 builds on the latter two to describe the form-related part of the lexicon of signs to be used in the work-package.

Revision History

Revision 1 (October 2001)

- Replaced graphics in ch. 4 by higher-resolution pictures

1 Introduction

One of the goals of the ViSiCAST project is to provide translation from English into sign language. As English on the one hand and the three target languages (British, Dutch, and German Sign Language) on the other hand are not closely related, it is our belief that only a deep translation can provide good-quality output. Therefore, we set up a system that extracts the meaning of the English input sentences and uses the resulting semantic representation to drive the generation process for the target sign language: By making the intermediate semantic representation as language-neutral as possible or even biased towards sign language, we aim to reduce the spoken-language influence on sign language production. The semantics representation formalism suggested here is based on Discourse Representation Theory as this theory makes structures explicit that are of major importance for sign language production. The formalism is presented in chapter 2.

A minimal translation system between two oral languages translates text into text. In the case of ViSiCAST, the situation is somewhat different as there is no established written form for sign languages.¹ Therefore, the system output is computer-animated signing, using the avatar technology developed in parallel in another ViSiCAST work-package.² This animation will be driven by a description of signed sentences encoded in an XML compliant language called SiGML (Signing Gesture Markup Language). Functionally, SiGML is a superset of HamNoSys, the Hamburg Notation System for sign languages.

The basic idea of SiGML, which will be described in extenso as Deliverable D5-2, is a timed and synchronized multi-tier representation of signed utterances where each tier encodes one of the parallel information channels signing makes use of: the hands, the body, the head, facial expressions, mouthing, and eye gaze.

The manual aspects of signs are described by HamNoSys notations. A new version of HamNoSys has been developed for the ViSiCAST project. Chapter 3 of this document describes in detail all the additions and revisions made to the predecessor, version 3. Knowledge of the earlier versions is therefore required. A self-contained documentation of the new version 4 will be published separately.

Non-manual aspects of signs can only partially be described in HamNoSys. Facial expressions, for example, would require a substantial number of new concepts to be introduced into HamNoSys. As multi-tier descriptions become readily available in language technology, a complete integration into HamNoSys, in the sense that a sign notation still consists of a string of characters, seems to be neither necessary nor desirable. Instead, the approach taken presents a number of coding sets for individual non-manual aspects and leaves it to the SiGML level to integrate them into composed events. This approach has the additional benefit of being easily extensible should it turn out that new codes for other sign languages or even our target sign languages become necessary, without affecting the much more mature coding of the manual aspects. Chapter 4 outlines the current proposal.

In the language generation process, the lexicon of the target language plays a central role. This is even more so for constraint-based grammar environments such as HPSG (Head-driven Phrase Structure Grammar) where in fact the major part of the knowledge about the language is stored in the lexicon instead of the grammar. The way sign languages make use of space renders it infeasible to store each inflected form of certain sign language verbs as separate entries in the lexicon. It is therefore necessary to follow the approach where lexicon entries can be inflected by rules to produce the form required in a given context. Chapter 5 outlines the structures and mechanisms necessary to produce a token that is then describable by means of the notations presented in chapters 3 and 4.

¹ A number of systems have been proposed, but even the probably most successful among them, SignWriting (see Sutton 1999), is not used within a larger community as an everyday writing system.

² This approach ensures that the system output can be judged by native users of the target language, a top priority for a faithful evaluation of the system.

So far, the languages presented have been described to interface between different components of the translation system. However, any of these can also become visible and editable to the (advanced) user of such a system:

As machine translation is a very complex field, and is even more so with less intensively researched target languages involved, one has to be very careful to define restrictions that reduce the complexity and thereby allow the project to reach its goal within a defined timeframe. Often, this is accomplished by defining a domain or a number of domains the translation system will be used in. In ViSiCAST, we take this approach as well. But in addition we suggest a system where the user can intervene wherever the automatic process does not provide correct results.

As the output of the translation system cannot be described conveniently and time-efficiently even by an experienced translator, the use of the system makes sense even if manual intervention is necessary. One possible scenario for this is the task to translate a web page into sign language. The translator uses the system by feeding in the source text, reviewing the output and modifying it where necessary. When finished, the SiGML description of the signed text is linked to the web page where it can be found by signing assistants.³

The following description outlines how such an integrated translation environment might look like. It should become obvious where the user can take advantage of the systems described in the following chapters of this document.

From a user's point of view, the translation process can be modelled as five steps, with the four inner states being editable to achieve the desired results.

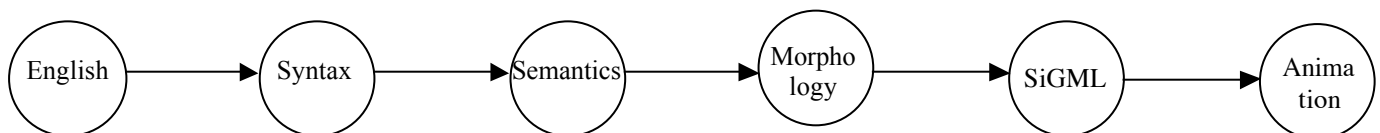

The user may freely move back and forth between the different states: Clicking on a tab further to the right implicitly starts the necessary compilation processes. Clicking on a tab to the left allows the user to go back to an earlier state to intervene there, thereby possibly voiding decisions taken for the states further down the line.

³ Signing assistants in the web contexts are handled in work-package 2 of the ViSiCAST project.

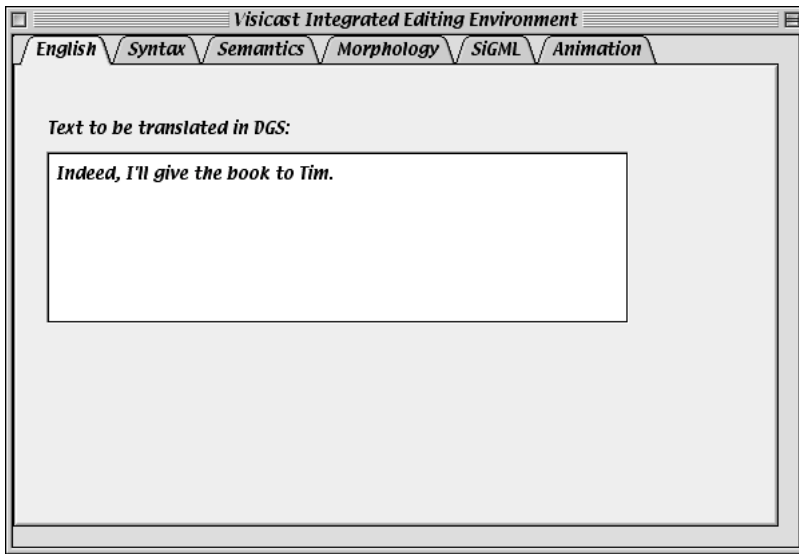

In the first state, English text is entered, either by typing it in or by pasting it in from some other source.

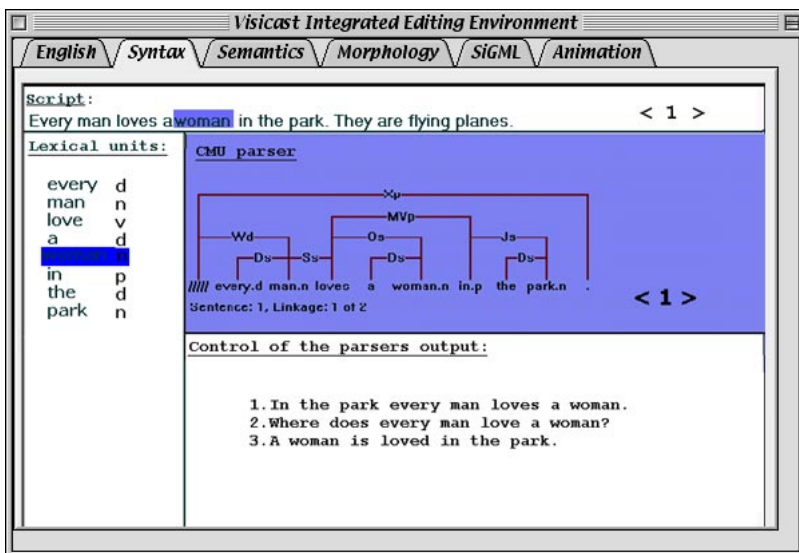

In the second state⁴, syntactic analysis of the input is presented to the user. The user can select from multiple readings and check the part of speech assignments.

⁴ Graphics footage for this and the next screen dump have been provided by Ian Marshall and Eva Safar from University of East Anglia.

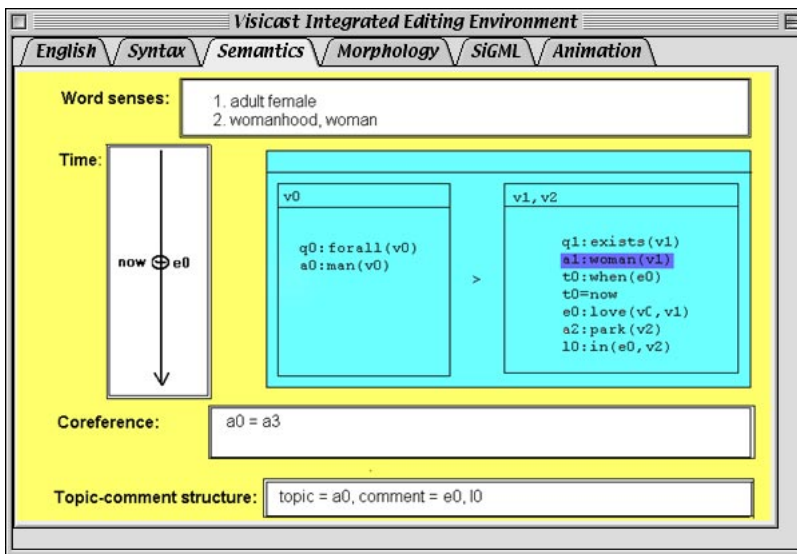

In the third state, the semantics of the input are presented. The top field contains word senses (WordNet), in which the user can pick the right word sense to avoid ambiguity. Co-references suggested by the system can be corrected here as well.

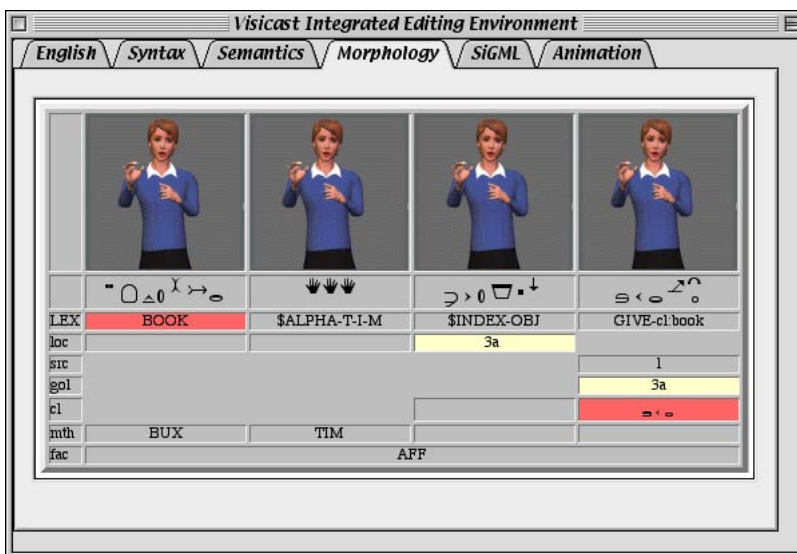

The next step translates Discourse Representation Structures into a morphological description of the output. Obviously, this is where most of the sign language generation takes place. The state after this step, Morphology, also seems to be the easiest spot to intervene in the generation process, hence we will later detail the operations the user should have available here.

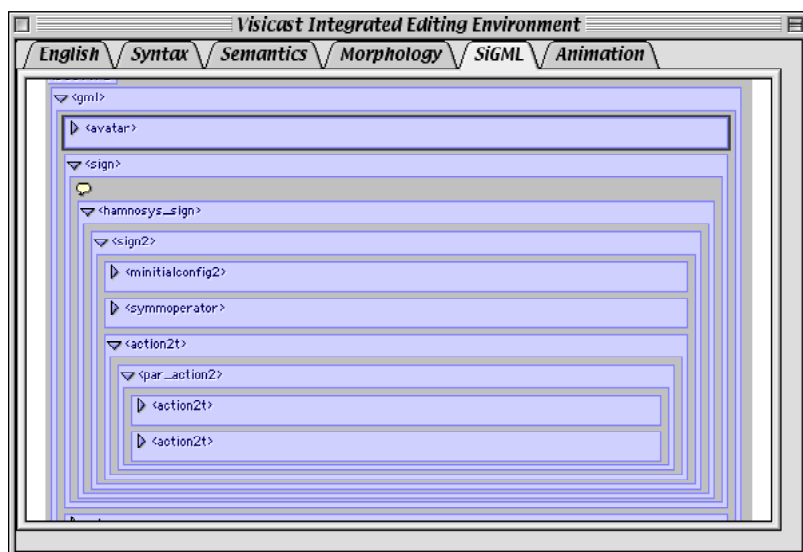

From the string of morpheme complexes, the SiGML representation of the output will be created. If necessary, the user can edit in this view as well although it is expected that sign language translators will prefer the morphemes view instead of having to deal with the technical details of an XML structure.



The final state is the end-product, the animation. If the animation shows problems, the user may go back to one of the earlier states to manipulate the data. If the result is as intended, the user can go back to the SiGML representation to copy the output to some other document.

Now to the central editing environment: the morphemes view. We consider it the most convenient place to intervene both for linguists and native signers as this view is quite close to the signing stream and communicates with the user in terms that are familiar or can become familiar to him/her.



The sign stream goes from left to right, with one column per sign.

The top two tiers describe the sign in its entirety, through the animation (with a thumbnail as placeholder) and through the HamNoSys notation. Clicking on the thumbnail plays the animation once.

The gloss is the key to the “stems” called from the lexicon whereas the following tiers show additional morphemes which are included in the sign. Colour-codes may be used for co-references.

The last tier in this sample shows suprasegmental information. This is not restricted to whole phrases, but may apply to any stretch of signs. There will definitely be more than one such tier.

Signs can be inserted, deleted, or rearranged in their order. Signs can be modified by assigning values to one of the tiers below LEX. The lexicon entry decides whether and how a certain tier can be filled for a particular sign. Some of the editors used for assigning values to the cells may be rather complex. For example, for the loc/src/gol morphemes, the user may select a position from a map of the horizontal plane in front of the signer on which previously used positions are marked.

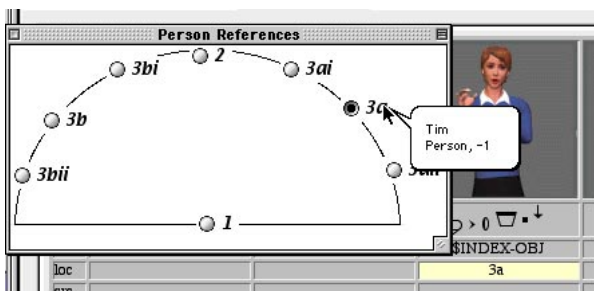

Inserting signs requires the user to identify a sign first. Several methods should be available:

- Search by gloss
- Search by meaning (browsing WordNet)
- Search by form (entering HamNoSys for the citation form)

In each case, partial entries may result in browsing lists from which the desired sign can be selected.

Alternatively, the user may choose to fully describe the sign by giving a HamNoSys notation. This may be achieved by typing in HamNoSys symbols or by a syntax-guided editor.

Suprasegmental features can be inserted and deleted as well. Additionally, they can be extended or shrunk sign by sign (using conventions for sub-sign timing).

Thomas Hanke, University of Hamburg, <mailto:thomas.hanke@sign-lang.uni-hamburg.de>

2 Semantics interface language

2.1 Sign Language Characteristics

The aim of the Natural Language Processing component of Work-Package 5 is to allow semi-automatic manipulation of English text to a representation oriented towards signed presentation (cf. Safar & Marshall, submitted). The overall architecture focuses on the use of Discourse Representation Structures (DRSs) as an inter-lingua in which sufficient semantic information is extracted from the input text or is volunteered by the user to support subsequent sign generation. The DRS representation is sufficiently rich to have removed lexical, structural and semantic ambiguity without over-burdening the English NLP component with pragmatic issues and world-knowledge inferencing which, if needed, must be volunteered by the user. The DRS representation isolates a number of semantic domains (events, states, nominal elements involved in these, locational and temporal information, etc) as well as indicating significant syntactic information (esp. sentence type). Sign Language synthesis is achieved by a subsequent conversion to a HPSG representation in which components of the DRS are regrouped into appropriate morphological components.

These DRSs capture characteristics that are significant in sign languages. In particular :

(i) pronominal reference, more general co-reference and placement. Repeated reference to the same individuals in a text can be replaced by references to positions in signing space. The DRS representation makes explicit anaphoric references by associating the same variable with multiple references across sentences/propositions. The sign space planner will then manage consistent allocation of such variables to significant positions in signing space.

(ii) organisation of the back-end dictionary as a ‘SignNet’ analogous to WordNet gives the potential of using classifier shapes as pronominal references inside signs for verbs which incorporate subject/object information. In BSL, such ‘proforms’ are usually associated with information about verb object roles.

(iii) BSL signals temporal information significantly differently from English. In particular, English tenses are not signaled in a comparable way in sign language. Hence, the semantic representation should be as accurate as possible with respect to temporal information to allow conversion to sign language using e.g. appropriate time lines (such as BSLs three/four major time lines).

(iv) BSL makes a significant grammatical distinction between a single event involving a group of objects and a repetitive event involving single objects. For example, the ambiguity of

The lecturer spoke to the students.

as either

The lecturer spoke individually to each student.

or

The lecturer spoke to the students collectively.

needs to be resolved in order to appropriately sign one of these alternatives. DRSs allow the explicit representation of the set and individuals of the set. It may be possible to determine from the surrounding context which of these is appropriate or may require human intervention, however the representation will have required that the ambiguity is resolved.

(v) Topic Comment Structure. Sign languages are reputed to have a topic-comment structure, hence we will look to deploy techniques which detect sentential and discourse topic. In the DRS this will be realised

by sentential indication of the new information by a predicate ‘comment’ which can be in later synthesise to organise the order of sign delivery.

The following characterisation is largely based upon the formulation of DRSs of Kamp and Reyle (Kamp & Reyle 1993, van Eijck & Kamp 1997) Labelling of propositions is an adaptation taken from Kamp & Reyle (1993), though in van Eijck & Kamp (1997) these are presented as an additional argument to each predicate. In general terms, this makes provision for their interval temporal framework coupled with first order predicate logic and extensions to allow sets of objects as arguments to predicates, plus any further extensions we might consider desirable. For example the labeling of attributive propositions merely extends Kamp and Reyle’s (1993) notation but allows the possibility of $[\text{attr1:big}(X)$ and $\text{very}(\text{attr1})]$ as ways of handling some modifiers. From a logical viewpoint this looks suspect but from a practical point of view, BSL facial expressions associated with intensity could be associated with such higher order predicates.

The description makes no provision for ease of identification of particular kinds of proposition, though we could agree to group these appropriately (e.g. all temporal relation propositions together etc.) .

The remainder of the chapter is structured as

- descriptions of how syntactic forms are realised in the DRS and hence the associated semantic form.
- example sentences and their DRS forms (generated by existing tools and with deviations from the descriptions here indicated)
- formulation of the DRS structure as a BNF description

2.2 Realisations of syntactic constructions in the DRS

Where possible illustrative cases are taken from the kitchen world example sentences.

2.2.1 Nominal constituents

1. Nouns are realised as a one place predicate (the noun itself) whose argument is a referent v_n , with a label a_n , e.g. glass

e.g. **$a(2):\text{glass}(v(2))$**

2. Plural nouns are similarly realised but with an additional relational expression for indefinite and numeric quantification, e.g. plates

e.g. **$a(12):\text{plate}(v(16)), c(0) = \text{count}(v(16)), c(0) > 1$**

3. In the case of numeric quantification the quantity is specified, e.g. five plates

e.g. **$a(12):\text{plate}(v(16)), c(0) = \text{count}(v(16)), c(0) = 5$**

[Currently, we do not process plurals like this and in example below they appear simply as

e.g. **$a(12):\text{plates}(v(16))$**

]

e.g.: **a(31):she(v(41))**

The resolution of pronouns happens after the DRS creation:

a(31):she(v(41))/a(33):Susan(v(42))

- b. reflexive

This point still has to be considered

- c. here/there

These pronouns are analyzed as locational verb modifiers.

e.g.: **l(1):here(e(2), v(4))**

- d. one

This pronoun is resolved in the following way:

a(0):cup(v(0)) a(1):one(v(1))/a(1):cup(v(1))

The predicate ‘one’ has to be resolved to ‘cup’, where they have different arguments/referents from the co-referential term (hence retain the variable associated with the original ‘one’ predicate).

2.2.2 Verbal constituents

7. Intransitive verbs are realised as a one place predicate (the verb itself) whose argument is a referent v_n , with a label e_n , e.g. walk

e.g. **e(4):walk(v(13))**

8. Transitive verbs are realised as a two place predicate (the verb itself) whose arguments are referents v_n, v_x , (n not equal x) with a label e_n , e.g. place

e.g. **e(2):place(v(15), v(16))**

9. 3 argument verbs are realized as 2 argument predicates like transitive verbs before (referents v_n, v_x). The indirect objects are realized like prepositional phrases with referents e_m and v_z .

e.g.: **e(2):give(v(4), v(5)), a(6):Peter(v(6)), l(2):to(e(2), v(6))**

10. Verbs involving particles are realised as a one or two place predicate (the verb+particle itself) whose arguments are referents v_n, v_x , with a label e_n , e.g. put his coat on / put on his coat

e.g. **e(2):put_on(v(15), v(16))**

11. Verb forms and auxiliary verbs are realised for their temporal information as a temporal one place (*when*) whose argument is the event (state?) $e_n, s_n?$, with a label e_n , e.g. placed

e.g. **t(8):when(e(2)), t(8)<now, e(2):place(v(15), v(16))**

and e.g. has placed

e.g. **t(8):when(e(2)), t(8)<now, t(8) ⊆now, e(2):place(v(15), v(16))**

12. Negation

E.g.: **[U_x] [Cond_x**

~ [U_y] [Cond_y]]

(It has to be noted that currently we do not promote proper nouns into the main DRS from the embedded DRS. This restricts the accessibility of the referent for anaphora resolution. E.g.: John does not have Ulysses. He likes it.)

2.2.3 Sentence types

13. Declarative

These are unmarked within the DRS, though the intention is to indicate topic-comment structure by a predicate **comment** with arguments e_x or s_x and $v_{y...z}$. This predicate might take more than two arguments if needed.

14. Imperative

- a. understood you – ‘you’ is introduced with a one argument nominal predicate (*you*) and a predicate **imperative** with one argument (e_n or s_n) explicitly into the sentence form. Hence imperative sentences appear as declarative sentences

e.g. **a(4):you(v(4)), e(2):put(v(4), v(5)), imp(0):imperative(e(2))**

- b. polite forms - ‘Would you (please)...’ forms can be translated as polite imperatives. *More generally we postpone deciding about other auxiliaries.*

15. Interrogative

- a. yes/no forms are realised as a one place predicate (*yesno*) whose argument is an event e_n or state s_n , with a label qu_n , e.g. Is the cup big

e.g. **qu(2):yesno(s(5)), s(5):be(v(13), v(14))**

- b. wh-interrogatives are realised as a one place predicate (the pronoun itself) whose argument is an event e_n or state s_n , with a label qu_n , e.g. Where did he place ...

e.g. **e(2):place(v(15), v(16)), qu(3):where(e(2))**

Note that the **when** predicate occurs in two contexts (temporal information derived from verb morphology, and here as interrogative predicate). However this time it has the label qu_n :

e.g.: **t(2):when(e(30)), t(2)=now, e(30):cook(v(59)), qu(4):when(e(30))**

- c. subject/object interrogative pronoun (who, what)

These interrogative pronouns are realized as wh-pronouns but they have v_x as argument and so the argument is introduced into the universe of the DRS:

E.g.: **qu(0):who(v(6))**

This realisation also means that they are considered as possible anaphoric referents. This is required: ‘Who cooks the meal? He must be very careful.’

2.2.4 Prepositional Phrases

16. Verb modifying

These phrases are realized as two place predicates. Temporal expressions like on+Day and in+Month have the predicate *time* while in other cases the predicate is a form of the preposition (see Semantics of Prepositions). The labels are t_x and l_x if the preposition is temporal or local respectively. The arguments are event, e_n or state, s_n and referent, v_n :

E.g.: on Sunday

a(3):Sunday(v(4)), t(5):time(e(3), v(4))

in the kitchen

a(5):kitchen(v(6)), l(3):in(e(4), v(6))

17. Noun modifying

These phrases are realized as two place predicates. They are very similar to verb modifying phrases, but the first argument of the predicate is a noun referent instead of an event or state:

E.g.: a man in the kitchen

a(56):kitchen(v(68)), l(4):in(v(67), v(68)), a(57):man(v(67))

18. Semantics of Prepositions

In the cases of prepositions, predicates will be unambiguous, hence the translation will determine the appropriate meaning of the preposition in the right hand column of the table below.

Preposition	Sense	semantics	label:predicate
in	in two hours	temporal	t_n :in
from	from Monday	temporal	t_n :from
to	to Monday	temporal	t_n :to
at	at the weekend	temporal	t_n :at
on	on Saturday	temporal	t_n :on
by	by Saturday by the start of the game	temporal	t_n :by
since	since the game	temporal	t_n :since
during	since the game	temporal	t_n :during
before	before the game	temporal	t_n : before
after	since the game	temporal	t_n : after
between	between 2 and 3 o'clock	temporal	t_n :between

for	since the game	temporal	t _n : for
for	for his aunt		p _n : for
to	walked towards	directional (near outside)	l _n :to
in inside	walked within	loc @ inside	l _n :within
in	into the house	directional (outside -> within)	l _n :into
inside			
into	into the house	directional (outside -> within)	l _n :into
into	into the lamppost	collide with	l _n :collide with
from	walked from the house	directional	l _n :from
out of	walked out of the house	directional (within -> outside)	l _n :out_of
above	above the box	loc	l _n :above
below ⁵	below the box	loc	l _n :below
by	by the box	loc	l _n :by
by	passive subject/agent		p _n :by
among	among the boxes	loc	l _n :among
with	with his aunt		l _n :with
without	without his hat		l _n :without

N.B. For the ambiguity of in/into/away ‘ran’ may be atypical with

John ran into Mary (= meet)

John ran away from his parents (= absconded)

Possible solutions at this stage to query the use

for CMU MVP in ask if (in=inside), or (=from outside to within)
 (though possible unnatural for ‘ran in the garden’)

for CMU MVP into ask if (into = collided with)

19. Relative Clauses

Relative clauses are represented in the main DRS, where the missing subject or object is resolved to the referent, which the clause refers to. This is indicated in the argument structure of the predicate of the embedded clause.

Object-type relative clause:

E.g.: The pan which he was using has disappeared.

⁵ under, beneath, beside, between, behind, in front of, opposite, near all comparable with above/below

```
[v(0), v(1)]
[
  a(0):he(v(1))
  t(0):when(e(0))
  t(0)=cont
  t(0)<now
  e(0):use(v(1), v(0))
  a(1):pan(v(0))
  t(1):when(e(1))
  t(1)<now
  t(1)$now
  e(1):disappear(v(0))
]
```

Subject-type relative clause:

E.g.: The pan which was clean has disappeared.

```
[v(5), v(6)]
[
  attr(0):clean(v(6))
  t(4):when(s(0))
  t(4)<now
  s(0):be(v(5), v(6))
  a(5):pan(v(5))
  t(5):when(e(4))
  t(5)<now
  t(5)$now
  e(4):disappear(v(5))
]
```

2.3 Examples

The following are sample DRSs generated by the current implementation for some sample sentences. Potential problems/ inconsistencies are indicated but are representative of proposed analyses. In particular, as our focus has not yet been on plurals, no DRS labels are generated currently.

2.3.1 Kitchen sentence examples

The glass is broken.

CMU dictionary changed to allow broken.a
as adj

sentence2

```
[v(2)]
[
  a(2):glass(v(2))
  t(1):when(e(0))
  t(1)=now
  s(0):broken(v(v(2)))
]
```

The salience values for the current sentence:

```
[ (a(2), 310)]
```

Former saliences:

```
[ ]
```

Updated with Coreference:

[]

Is the cup big?

Note that the attribute has a different referent than the noun. They are then equated by the state predicate 'be'

sentence8

[v(13), v(14)]

[
 a(10):cup(v(13))
 attr(4):big(v(14))
 qu(2):yesno(s(5))
 t(7):when(s(5))
 t(7)=now
 s(5):be(v(13), v(14))
]

The salience values for the current sentence:

[(a(10), 310)]

Former saliences: []

Updated with Coreference: []

Where did he place the large plates?

sentence9

[v(15), v(16)]

[
 a(11):he(v(15))
 attr(5):large(v(16))
 a(12):plates(v(16))
 t(8):when(e(2))
 t(8)<now
 e(2):place(v(15), v(16))
 qu(3):where(e(2))
]

The salience values for the current sentence:

[(a(11), 310), (a(12), 280)]

Former saliences:

[]

Updated with Coreference:

[]

There are knives in the sink.

sentence10

[v(17), v(18)]

[
 a(13):knives(v(17))
 t(0):when(s(6))
 t(0)=now
]

```

s(6):be(v(17))
a(14):sink(v(18))
l(2):in(s(6), v(18))
]

```

The salience values for the current sentence:
[(a(13), 280), (a(14), 210)]

Former saliences:
[]

Updated with Coreference:
[]

The knives in the sink are dirty.

sentence11

```

[v(19), v(20), v(21)]
[
  a(15):sink(v(20))
  l(3):in(v(19), v(20))
  a(16):knives(v(19))
  attr(6):dirty(v(21))
  t(1):when(e(3))
  t(1)=now
  e(3):be(v(19), v(21))
]

```

The salience values for the current sentence:
[(a(16), 310), (a(15), 210)]

Former saliences:
[]

Updated with Coreference:
[]

The large plates are beside the small plates.

sentence1

```

[v(0), v(1)]
[
  attr(0):large(v(0))
  a(0):plates(v(0))
  t(0):when(e(0))
  t(0)=now
  s(0):be(v(0))
  attr(1):small(v(1))
  a(1):plates(v(1))
  l(0):beside(e(0), v(1))
]

```

The salience values for the current sentence:
[(a(0), 310), (a(1), 210)]

Former saliences:

[]

Updated with Coreference:

[]

 Do you have a oven?

sentence2

```
[v(2), v(3)]
[
  a(2):you(v(2))
  q(0):exists(v(3))
  a(3):oven(v(3))
  t(1):when(e(1))
  t(1)=now
  e(1):have(v(2), v(3))
  qu(0):yesno(e(1))
]
```

The salience values for the current sentence:

[(a(2), 310), (a(3), 280)]

Former saliences:

[]

Updated with Coreference:

[]

 Put the pot from the oven into the cupboard.

Imperative label missing

sentence3

```
[v(4), v(5), v(6), v(7)]
[
  a(4):you(v(4))
  a(2):pot(v(5))
  t(0):when(e(2))
  t(0)=now
  e(2):put(v(4), v(5))
  a(3):oven(v(6))
  l(0):from(e(2), v(6))
  a(4):cupboard(v(7))
  l(1):into(e(2), v(7))
]
```

The salience values for the current sentence:

[(a(4), 310), (a(2), 280), (a(3), 210), (a(4), 210)]

Former saliences:

[]

Updated with Coreference:

[]

 I wash the dishes.

sentence4

```
[v(8), v(9)]
[
  a(5):I(v(8))
  a(6):dishes(v(9))
  t(1):when(e(3))
  t(1)=now
  e(3):wash(v(8), v(9))
]
The salience values for the current sentence:
[ (a(5), 310), (a(6), 280)]
Former saliences:
[ ]
Updated with Coreference:
[ ]
```

2.3.2 Example DRS produced for earlier screen shots

Every man loves a woman in a park.

```
drs([],
  [drs([v(0)], [q(0):forall(v(0)),
                a(0):man(v(0))]) =>
    drs([v(1), v(2)], [q(1):exists(v(1)),
                       a(1):woman(v(1)),
                       t(0):when(e(0)),
                       t(0)=now,
                       e(0):love(v(0), v(1)),
                       q(2):exists(v(2)),
                       a(2):park(v(2)),
                       l(0):in(e(0), v(2))])
  ])
```

(Variable and proposition labels as ‘lab(n)’ rather than ‘labn’ is merely due to convenience of processing currently. Currently only referent variables v1,v2 are listed in the variable lists).

2.3.3 Example illustrating resolution of anaphora

Put the pot from the oven into the cupboard. Is it dirty?

```
[
  [ a(4):it(v(4))/a(1):pot(v(1)) ] co-reference of a4 and a1 (v4 and v1)
  [v(0), v(1), v(2), v(3)] Put the pot from the oven into the cupboard.
  [
    a(0):you(v(0))
    a(1):pot(v(1))
    t(0):when(e(0))
    t(0)=now
    e(0):put(v(0), v(1))
    a(2):oven(v(2))
    l(0):from(e(0), v(2))
    a(3):cupboard(v(3))
    l(1):into(e(0), v(3))
  ]
  [v(4), v(5)] Is it dirty?
  [
```

```

a(4):it(v(4))
attr(0):dirty(v(5))
qu(0):yesno(s(0))
t(1):when(s(0))
t(1)=now
s(0):be(v(4), v(5))
]
]

```

2.4 DRS BNF / Ontology

DRSmultsent ::= [*VariableBindings* , [*DRSsent* , *DRSsent*]]

VariableBindings ::= [*NominalAttributiveProposition* / *NominalAttributiveProposition*]

(currently only provision for coreference of nominals, to consider later anaphoric relationships with events, etc)

DRSsent ::= *drslabel* : [*VariableList* , [*SententialProposition* , *LabeledPropositions*]]

SententialProposition ::=

```

ImpVar : imperative ( Evar ) |
QuVar : yesno ( [ Evar | Svar ] ) |
QuVar : whPred1 ( [ Evar | Svar ] ) |
QuVar : whPred2 ( Var )
CommVar : comment ( Var )

```

comment() for declaratives

whPred1 ::= { **when, how, why** }

whPred2 ::= { **who, what, which** }

VariableList ::=

To consider format
List of all variables / labels used in the DRS
Possibly segmented into different categories for ease of extraction.
Currently we only generate variables v_n in the variable lists.

LabeledPropositions ::=

```

LabeledProposition |
LabeledProposition , LabeledPropositions |
DRS ⇒ DRS

```

(last production may have undesirable consequences, permitting *LocationalPropositions*, *CollectivePropositions*, *ReferentRelationProposition*, *TemporalRelationProposition* as antecedents - possibly need to subcategorise.)

LabeledProposition ::=

```

QuantifiedVariable |
EventProposition |
StateProposition |
TemporalProposition |
LocationalProposition |

```

SymbolicLocationalProposition |
OtherPrepProposition |
NominalAttributiveProposition |
AttributiveProposition |
CollectiveProposition |
NumericalQuantifiedDefinition |
ReferentRelationProposition |
TemporalRelationProposition

EventProposition :-
Evar : *Proposition*

StateProposition :-
Svar : *Proposition*

TemporalProposition :-
Tvar : **time** ([*Evar* | *Svar*]) |
Tvar : *TemporalPredicate* (*Evar*, *Var*)
(*Tvar* denotes an interval)

TemporalPredicate :-
in | **on**

LocationalProposition :-
Lvar : *LocationalPredicate*(*Evar*, *Var*) |
Lvar : *DireactionalPredicate*(*Evar*, *Var*)

DirectionalPredicate :-
to | **from** | **into** | **out_of**

LocationalPredicate :-
within | **on** | **above** | etc.

SymbolicLocationalProposition
SLVar : *LocationalPredicate* (*Evar*, *Var*)
/* following Hungarian nomenclature, these are for pseudo locational uses of
prepositional phrases, ‘in a hat’, ‘in a good humour’, ‘on the phone’ – essentially
a place holder for further thought. */

OtherPrepProposition
PVar : *OtherPrepPredicate* (*Evar*, *Var*)

LocationalPredicate :-
for | **by** | **with** | **without**

AttributiveProposition :-
Avar : *Proposition*

NominalAttributiveProposition :-
Nvar : *Proposition*

CollectiveDefinition :-
Cvar = **count**(*Var*) |
Cvar = **count**(*Var* , *drslabel*)
 /* Use of the box notation, potentially requires DRSs to be labeled for
 restricting predicates for plurals – see Kamp & Reyle (1993:343).
 requires further thought. */
 #*Cvar* > 1

NumericalQuantifiedDefinition :-
Cvar = **count**(*Var*) |
Cvar = **count**(*Var* , *drslabel*)
 /* Use of the box notation, potentially requires DRSs to be labeled for
 restricting predicates for plurals – see Kamp & Reyle (1993:343).
 requires further thought. */
 #*Cvar* = N

ReferentRelationProposition :-
Var = *Var* | *Var* \in *CVar*

TemporalRelationProposition :-
Tvar *TemporalOperator* *Tvar*

TemporalOperator :-
 = | < | > | \subseteq | \supseteq
 (temporal precedence and inclusion)
 (possibly others for completeness)

Proposition :-
Predicate (*VarList*)

QuantifiedVariable :-
UniversalQuantification |
ExistentialQuantification

UniversalQuantification :-
Qvar : \forall *Var*

ExistentialQuantification :-
Qvar : \exists *Var*

Predicate :-
PredName . *Sense*

PredName :-
 A lexical base form

Sense :-
 An item identifying the sense of the lexical item and the specific sense according
 to that source (e.g. Wordnet.3)

VarList :-

Var |
Var, *VarList*

Where

Var ∈ {v1,v2,v3, }
Evar ∈ {e1,e2,e3, }
Svar ∈ {s1,s2,s3, }
Tvar ∈ {t1,t2,t3, }
Lvar ∈ {l1,l2,l3, }
Qvar ∈ {q1,q2,q3, }
Nvar ∈ {a1,a2,a3, }
Pvar ∈ {p1,p2,p3, }
Avar ∈ {attr1,attr2,attr3, }
Cvar ∈ {c1,c2,c3, }
drslabel ∈ {drs1,drs2,drs3, }
ImpVar ∈ {imp1,imp2,imp3, }
QuVar ∈ {qu1,qu2,qu3, }
CommVar ∈ {comm1,comm2,comm3, }

Ian Marshall, University of East Anglia, <mailto:im@sys.uea.ac.uk>
Eva Safar, University of East Anglia, <mailto:es@sys.uea.ac.uk>

3 Encoding manual aspects of sign language: HamNoSys 4.0

3.1 Background

The Hamburg Notation System (HamNoSys) is a well-established phonetic transcription system for sign language which comprises of more than 200 iconically motivated symbols. It was developed at the Institute of German Sign Language in the 1980s (first version published in 1987: Prillwitz et al. 1987) for the transcription of individual signs as well as sign utterances for research purposes. One of the design goals was to make it applicable for all sign languages.

So far, HamNoSys has been used as a notational basis in a number of gesture research projects, e.g. Hofmann & Hommel (1997) and Fröhlich & Wachsmuth (1998). However, in the context of sign language generation, ViSiCAST is the first project to use HamNoSys for storing the phonetic form of individual signs in the lexicon and for combining signs into sign language utterances. This decision was taken early in the project design phase for several reasons: First, HamNoSys has proven quite stable over the last years and certainly is among the most frequently used notation systems within the sign linguistics community world-wide (cf. Miller to appear). Secondly, any notation that is too tightly connected to a specific phonological theory is too high a risk as a basis for a three-year project. In addition, most phonological theories have only been tested against ASL, not any of the European sign languages, and there has been no attempt to use such a system for more than one language. (In fact, targeting a phonological system to more than one language would presuppose that their phonological inventory is identical.) Most importantly, partners have employed native signers or have native signers associated with the project who are already familiar with HamNoSys. Therefore, native signers' intuition about the correctness of utterances generated by the ViSiCAST translation system can be used before the animation machine (developed in other work-packages of the project) can render signs from notation faithfully enough to evaluate the generation as such. Finally, HamNoSys notations are sufficiently compact and easy to type in order to be used in the integrated editing environment (cf. scenario in chapter 1).

As a consequence, one of the first milestones in the language & notation work-package was to further develop the kernel part of HamNoSys, i.e. the description of manual aspects, in order to fill minor gaps in previous versions as well as to satisfy some of the needs of using the system in a generation process. The major motivations for the changes include the aim for a more natural representation of signs, the possibility of underspecification in the notation, and the possibility of co-reference within a text. This often results in shorter HamNoSys strings. Backwards compatibility is required due to the large amount of HamNoSys transcriptions by various research groups.

The following description assumes that the user has some familiarity with HamNoSys 2 (Prillwitz et al. 1989) and HamNoSys 3 (Hanke 2000). A self-contained documentation of HamNoSys 4 is in preparation.





3.2 Handshapes in HamNoSys 4.0

3.2.1 New bending operators

Two new symbols are added to the already existing three bending operator symbols: \checkmark and $\hat{\quad}$.

The inventory of bending operators is as follows:

	base joint	middle joint	distal joint	
\hookleftarrow	max.ext.	max.ext.	max.ext.	no bending (default)

	max.bent	max.ext.	max.ext.	bent
	half-bent	half-bent	half-bent	round
	max.ext.	max.bent	max.bent	hooked
	max.bent	max.bent	max.ext.	double-bent
	max.bent	max.bent	max.bent	double-hooked

Note that all bending operators cover a certain range of bending.⁶

• Intermediate forms

There will be no new symbol for intermediate forms such as $\hat{O} \setminus \hat{O}$. All bending operators cover a certain range of bending. Likewise, a hand with extended fingers and no bending symbol can also be used to transcribe a hand with slightly bent fingers. If necessary, intermediate forms can still be notated with the in-between operator \setminus .

How these symbols are applied:

• Fist

The \hat{O} symbol makes the differentiation between the two different positions of the fingers in a fist possible, i.e.:

- O fist with the nails touching the palm = default (as before); and
- \hat{O} the fist with the finger pads touching the palm (this almost always also requires some contact with the distal joint). This latter handshape could also be notated HamNoSys as \hat{O} ; it was decided, however, to use the fist symbol in order to show the close relationship between the two different handshapes.

• Fingers [+ spread]

The bending operator \checkmark for “fisting” (double-hooked) is used, for example, to differentiate between the two different productions of the “Y”-handshape:

- \checkmark^5 where the little finger is [- spread] (i.e. position as in \checkmark^{45}); and
- $\checkmark^{45\checkmark}$ where the little finger is [+ spread] (i.e. position as in \checkmark^{45}).

⁶ Max.ext. = joint maximally extended; max.bent = joint maximally bent; half-bent = joint approx. 45° bent

thumb in the plane, across



The thumb-orthogonal symbol may not only be used in combination with the base symbols but also with the other symbols. This will obviously lead to quite some overlap of symbols.

- Thumb-finger combinations [\pm spread]

One can now differentiate between $\overline{\llcorner}$ and $\overline{\lrcorner}$. The latter equals $\overline{\supset}^{23}$. I.e. thumb-finger combinations in which more than one finger is involved are defined as being [- spread]. If one wants to show [+ spread] this is transcribed with individual finger handshapes and the opposed thumb.

Different degrees of opening in these handshapes will look as follows:

open <----->closed

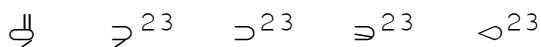

- Opposition/contact in thumb-finger combinations

In thumb-(single)finger combinations where more than the default finger is involved (e.g. \llcorner^{23} or \supset^{23} or \supset^{345} or \supset^{34}), if there is a need to indicate which finger the thumb is opposed to, this can be done by using the \bullet symbol as follows:

- $\llcorner^{\bullet 23}$ thumb contacting index finger
- $\supset^{\bullet 23}$ thumb in opposition to the middle finger
- $\supset^{\bullet 345}$ thumb in opposition to the ring finger
- $\supset^{\bullet 34}$ thumb in opposition to the middle finger

In HamNoSys 2.0, contact information in closed thumb-all fingers combinations was already defined; it was notated as, e.g.:

\llcorner^2 thumb contacting index finger

To conform with the newly introduced notation convention we suggest to also use the \bullet symbol in these cases (not obligatory, however), e.g.

$\llcorner^{\bullet 2} \mid \llcorner^2$ thumb contacting index finger

The same notation can also be used in open thumb-all fingers combinations, e.g.

$\supset^{\bullet 3} \mid \supset^3$ thumb in opposition to the middle finger

- Opposition in open hands with opposed thumb

For open hands with opposed thumb, the • symbol will also be used, e.g:

 thumb in opposition to the index finger

 thumb in opposition to the middle finger

 thumb in opposition to the ring finger

3.2.3 Un(der)specified handshapes and handshape groups

- Un(der)specified handshape

We have introduced a new subscript which can be added to the non-dominant-hand symbol: 

In one-handed signs, it means that the hand is relaxed: any handshape between a half-open fist (with or without contact of the thumb and the fingers) and a slightly bent/curved 5-hand or flat hand.

In two-handed signs, it means that the non-dominant hand is either relaxed (see above) or that it copies the handshape of the dominant hand.

- Underspecified handshapes (handshape groups)

The same subscript can be used with basically any handshape (although we expect it rather to be added to the less marked handshapes) to signify that not necessarily the handshape notated is to be performed but anything within a certain range of that handshape, e.g.:

 may imply, for example {  |  |  |  |  |  |  }

 may imply, for example {  |  |  |  |  |  }

(see also 3.3.2 Underspecified orientation, 3.4.7 Underspecified locations, and 3.5.6: Repetition)

3.3 Orientation in HamNoSys 4.0

3.3.1 Relative orientation

Relative orientation means that the relation of the extended finger orientation or of the palm orientation to the path of the movement remains the same – either it is parallel with it or orthogonal to it. To abbreviate the notation of such signs in which the orientation changes constantly during the movement (e.g. in signs with a zigzag or a wavy movement), a new subscript is introduced: ~

Notation of signs will look as follows, for example:

..  BALL (“ball”)

..  HAUS (“house”)

..  KASTEN (“box”)

 WELLEN (“waves”)

In signs which exhibit a change from relative orientation to absolute orientation (we think that there are only few examples of this type), the notation will look as follows:

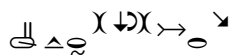
..  (no gloss – phantasy-sign)

Note: Another option would have been to use another symbol (e.g. the “natural sign”) to indicate the change back to absolute orientation.

3.3.2 Underspecified orientation

The subscript we have introduced for underspecified handshapes can also be used with the orientation symbols to signify that not necessarily the orientation notated is to be performed but anything within a certain range of that orientation, e.g.  may imply: $\{ \left| \ominus \right| \left| \circ \right| \}$

(see also 3.2.3 Un(der)specified handshapes and handshape groups)

3.4 Location in HamNoSys 4.0

Some new symbols are added, others will no longer be used (they are, however, still available).



3.4.1 Mouth: tongue, teeth

Two new symbols have been added to differentiate between the different locations on (and in) the mouth, namely

 tongue, and

 teeth.

3.4.2 Mouth, teeth, eyes

 and  will be used to differentiate between the upper part of the eyes, mouth and teeth respectively, i.e.:

 upper lip; and

 lower lip

 upper teeth; and

 lower teeth

 upper eyelid; and

 lower eyelid

These diacritics are restricted to the above group of location symbols; they may not be used with any other location symbol. In case one wants to be more specific, in-between locations have to be notated, e.g. if a sign is produced on the lower part of the shoulder region one can notate: □\ ▣ (as before).

3.4.3 Other locations

New symbols are added:

▣ on top of the shoulder (the upper surface of the shoulder)

Ⓛ ear lobe

Ⓜ under the nose (the lower surface of the nose)

In signs where one wants to be very specific about the location of each finger, e.g. as in the sign SPITZ(-NASE) (“pointed nose”) where the index finger is located on top of the nose, the thumb under the nose, the notation will look as follows: [Ⓜ(χ₂) Ⓜ(χ₁)]

3.4.4 Upper arm, elbow: front and back, right and left

The elbow-outer-side symbol Ⓛ is abolished. It will be notated as Ⓛ↻.

(Note that the old symbols still exist in the font for compatibility reasons.)

Upper arm and elbow will use the same reference system as the trunk:

	front (=default)	back	right	left
upper arm	Ⓛ	Ⓛ↻	Ⓛ◻	◻Ⓛ
elbow	Ⓛ	Ⓛ↻	Ⓛ◻	◻Ⓛ

3.4.5 Fingers, wrist, forearm: dorsal and palmar side, right and left

The following location symbols are abolished: ◻ and ↻

They are now transcribed as follows:

◻ ≡ ◻~

↻ ≡ ~

(Note that the old symbol ↻ still exists in the font for compatibility reasons and that ↻ continues to be used in handshape notations.)

For all fingerparts, the wrist and the forearm, one can notate the dorsal and palmar side by using the back-of-the-hand symbol and the palm symbol respectively. (If no specification is needed, the fingerpart, wrist or forearm symbols are used without any other symbol.)

- ☐~ fingernail
- ☐~ fingerpad
- ☐~ middle joint (dorsal side)
- ☐~ middle joint (palmar side)
- ☐~ base joint (dorsal side)
- ☐~ base joint (palmar side)
- ~ ball of the thumb (dorsal side)
- ~ ball of the thumb (palmar side)
- ~ wrist (dorsal side)
- ~ wrist (palmar side)
- ~ forearm (dorsal side)
- ~ forearm (palmar side)

The symbol ☐ meaning “side of finger” will not be used any more as a location symbol. Instead, the “right of” and “left of” symbol (◻) will be used.⁷ Reference for the finger sides will be the ulnar and radial side of the hand, i.e. the transcription for each hand will look different, for example:

right hand:		left hand:	
2◻	the ulnar side of the index finger	2◻	the radial side of the index finger
◻2	the radial side of the index finger	◻2	the ulnar side of the index finger

For the palm, wrist and forearm, the same reference system will be used:





right hand:

- ~◻ the ulnar side of the wrist
- ◻~ the radial side of the wrist

⁷ Note that in handshape transcriptions such as ☐²☐³☐⁴☐⁵ the symbol will still be used.

3.4.6 Fingers and fingerparts: order of symbols in the transcription

In earlier versions of HamNoSys, finger-number and fingerpart symbols could appear in any order in a notation. This is now changed, and there is a fixed order for these symbols: finger-number fingerpart, e.g.:

- 1  fingernail of the thumb
- 1  middle joint of the thumb
- 2  radial side of the middle joint of the index finger
- 2  ulnar side of the middle joint of the index finger

3.4.7 Underspecified locations

The subscript we have introduced for underspecified handshapes can also be used with the location symbols to signify that the area in which a sign is performed is larger than normal, e.g.:

 as a location may imply, for example {  |  \  |  \  |  .  .  }

(see also 3.2.3 Un(der)specified handshapes and handshape groups)

Note: Any location symbol refers to a certain area; adding the subscript signifies that the respective area is enlarged. What the exact range of an area is depends on each location (symbol); i.e. the nose with the subscript covers an area which is significantly smaller than an area covered by a body location symbol with the subscript.

3.4.8 Co-reference





For the transcription of texts one may wish to use indices for certain locations to which the hand returns later on in the narration. These locations will be numbered (12345). When a location is used for the first time it will be tagged, i.e. after the movement symbol a number will appear in a rectangular: 

When, later on, the same location is used (as target location etc), the number will appear in a circle. 

In double-handed signs, notated with a symmetry operator, reference to the location of the dominant hand will be with the circle (see above); and reference to the location of the non-dominant hand will be with the circle in combination with the non-dominant hand symbol. 

3.5 Movement in HamNoSys 4.0

3.5.1 Zigzag and wavy line movements

In previous versions of HamNoSys, zigzag and wavy line symbols (, ) could only be added as modifications to straight movements. They may now also be added to arc and circular movements, e.g.  or .

3.5.2 Tilde-symbol:

This symbol can be used in two different contexts with two different meanings:

- to indicate repetition

~ appears at the end of a movement transcription (where the other repetition markers appear) and carries the meaning: “Do with the non-dominant hand what you have just done with the dominant hand and vice versa”, e.g.: HANDSCHUH (“glove”): $\cup^{[...]} \sim$

If the movement is repeated with the non-dominant hand and then again repeated with the dominant hand, the repetition marker is added twice: $\cup^{[...]} \sim \sim$

- to indicate out-of-phase movements

~ appears directly after the symmetry operators, e.g. GEBÄRDEN (“to sign”): $\overline{\cdot} \sim \cup^{[...]}$

This influences both the movement and the starting position.

3.5.3 Brushing contact during a movement

For brushing contact during a movement a new symbol is introduced: \downarrow

Syntactically, these movements will be notated as follows:

MOV (brushing-MOV-symbol LOC-at-which-the-brushing-happens) {End-LOC}, e.g.

KAUFEN $\downarrow \cup^{(\downarrow \sim)} X$

The symbol may also be used in signs which have an “almost-brushing” contact, i.e. which move close to a certain body part, e.g. $\downarrow \cup^{(\downarrow \sim)} () +$

3.5.4 Bouncing movement

In some signs the hand moves in one direction (in most cases probably onto the non-dominant hand – but it may also be a movement in space) and then bounces back. For this bouncing movement, the following notation will be introduced:

$\downarrow \sim \cdot$ movement onto palm and bouncing back

$\downarrow \parallel$ movement in space with sudden stop and bouncing back

3.5.5 Fusion of movements

New brackets $\langle \rangle$ are introduced for the notation of those signs in which movements are fused, i.e. where there is no pause between one movement and the following movement, e.g.

$\langle \leftarrow \sim \rightarrow \rangle$ KANN-NICHT (“unable to do”)

This is also very useful in signs where the hand describes uncountable small movements in space, for example DIE-FLIEGE-FLIEGT-DURCH-DEN-RAUM (“the fly flies through the room”).

In signs in which only the dominant hand moves onto the non-dominant hand and then continues the movement together with the dominant hand, these brackets can also be used to describe that the movement of the dominant hand is an uninterrupted movement, e.g.

$\langle [\downarrow \otimes] \downarrow \parallel \rangle$ (phantasy-sign)

3.5.6 Repetition

- Combination of back-and-fro-movements

Movements such as MOV – back-MOV – MOV will be notated as follows, e.g.: $\rightarrow \leftarrow \leftarrow \leftarrow$ or $\bullet \left(\uparrow \circ \leftarrow \leftarrow \right)$

- Movement repetitions with offset

$\downarrow (\leftarrow \rightarrow)$ Downward movement which is repeated several times while moving to the right (the beginning location is always the same).



$\downarrow (\leftarrow \rightarrow)$ Downward movement which is repeated several times while moving to the right (the end location of the first movement is the beginning location of the second movement, and so forth).



Other examples include:

$\downarrow (\leftarrow \rightarrow) \searrow$

$\downarrow (\leftarrow \rightarrow) \searrow$

$\downarrow (\leftarrow \rightarrow) \searrow$

- Non-specified repetitions in space

In some signs, repetition can be in a non-specific manner, e.g. a sign can be repeated at various locations – where exactly is not important. For this we will use the same subscript as for the underspecified handshapes ... but add it as a subscript to the repetition symbol, e.g.:

$\circ \left| \rightarrow \ominus \left(\left(\leftarrow \rightarrow \right) \leftarrow \right) \leftarrow \right) \leftarrow \dots$ This is an example from Hausa Sign Language: TAURARUWA (“star”).

Note: In this notation there is no specification on which line or plane the repetition is performed. If one wants to indicate the plane in which the repetition takes place this can be done by using the \ominus \oplus symbols for horizontal and vertical plane respectively, e.g.

$\uparrow(\oplus\ominus)$
... GIVE (on a horizontal plane, e.g. to various people)

$\uparrow(\oplus\ominus)$
... GIVE (on a vertical plane, e.g. to God and the devil, among others)

If the movement is repeated at random but always uses the same target location, the notation will look as follows:

$\downarrow\uparrow(\oplus\ominus)$
... (something like: “several people coming towards the signer from different directions”)

3.5.7 Wrist movements / lower arm rotation

For movements in the wrist (right–left, up–down) two new symbols are introduced (which were already available in HamNoSys Version 1.0): \leftrightarrow \updownarrow . They will be used to notate repeated uncountable movements in the wrist (it doesn't matter in which direction the hand moves first), e.g.:

\leftrightarrow right–left example in DGS: WER (“who?”)

\updownarrow up–down example in DGS: WINKEN (“wave” vb.)

If the wrist moves in one direction only, this will be notated with changes in the orientation (as has been before), e.g.: KLOPFEN (“knock”) $\ominus \triangle \ominus \rightarrow \downarrow \uparrow$

(Likewise for countable movements in the wrist and for signs in which the direction of the first movement is important.)

For the rotation of the wrist and lower arm (repeated, uncountable, direction in which the rotation begins is irrelevant), e.g. in SPIEGEL (“mirror”), a new symbol is introduced: Ψ

Rotating (circling) the wrist as in RÜHREN (“stir”) or PROPELLER (“propeller”) will be treated differently. There are two symbols, one for each direction: \curvearrowright \curvearrowleft

The symbols refer to a single movement only. If there is repeated movement, the repetition symbols have to be added in the notation.

Rotating (circling) the wrist continuously in right direction while drawing a large circle in space:

$\ominus \triangle \ominus \curvearrowright \Psi \oplus$

The same symbols may also be used for rotating (circling) a finger, e.g.

$(\curvearrowright \Psi \oplus)$

3.5.8 Fingerplay

The fingerplay symbol can now also be used for signs like KRÜMELN (“crumble”), i.e. for thumb-finger combinations in which the selected fingers and the thumb are [+closed] (i.e. $\curvearrowright \curvearrowleft \curvearrowright$), resulting in some rubbing of the thumb and the fingers, e.g.

SALZ (“salt”) (and related signs): $\curvearrowleft \triangle \ominus \text{✋}$

If there is a sign with a [+closed] handshape in which the non-selected fingers wiggle, this needs to be notated as follows, e.g.: $\curvearrowright \triangle \circ \text{ } ^{(345 \text{ } \text{✋})}$ or $\curvearrowright \text{ } ^{34} \triangle \circ \text{ } ^{(25 \text{ } \text{✋})}$

3.5.9 Handshake change: Extending (or closing) one finger after the other

In handshake changes from fist to open spread hand or open spread hand to fist in which the fingers are extended / closed one after the other, e.g. in DGS TÄGLICH (“daily”) (extending the fingers) and KLAU-EN (“steal”) (rolling up fingers), we will notate the beginning and the end handshapes together with one of the two HamNoSys-symbols: $\triangleleft \triangleright$

\triangleleft from the thumb side to the little finger side

\triangleright from the little finger side to the thumb side

Examples:

$\circ \curvearrowright \triangleleft \text{ } \text{✋}$ index finger is extended first (2345)

$\circ \curvearrowright \triangleleft \text{ } \text{✋}$ thumb is extended first (12345)

$\circ \backslash \curvearrowright \triangleleft \text{ } \text{✋} \curvearrowright \text{ } \text{✋}$ index is extended first, thumb is extended last (23451)

$\circ \curvearrowright \triangleright \text{ } \text{✋}$ little finger is extended first (54321)

$\text{ } \text{✋} \curvearrowright \triangleright \text{ } \circ$ little finger is closed first (54321)

$\text{ } \text{✋} \curvearrowright \triangleleft \text{ } \circ$ thumb is closed first (12345)

3.6 Other: Ipsilateral (signer space) vs. right (real space)

We have introduced a symbol which will be added as a prefix to the notation of a sign (in two-handed signs after the symmetry operator symbol): ^{r}

It symbolises that the orientation and direction of movement are absolute/refer to real space and not to the signer space (the ipsilateral side), i.e.: the switch of orientation and direction of movement which usually takes place if a left-handed signer performs the sign notated for a right-handed signer should NOT be performed.

If for some reason one only wants to reverse the orientation but not the direction of movement, the notation will look as follows:

$\text{ }^{\text{r}} \text{ } \circ \curvearrowright \text{ } \text{ }^{\text{r}} \text{ } \circ \rightarrow$

3.7 Implementation

The HamNoSys character set has been available as a TrueType font usable on Macintosh as well as Windows platforms and all Unix systems that support TrueType fonts since version 3. On the

Macintosh, it was embedded into a script system (aka Language kit) to automatically switch keyboard to a graphical layout, to adapt sorting routines etc. All of these components have been updated to include the new version 4 characters. The keyboard layout is a compromise between changing as few keys as possible compared to version 3 and the most natural layout for the whole new set.

For the ANSI keyboard (used in the U.S.), some keys have been duplicated onto the numerical pad.

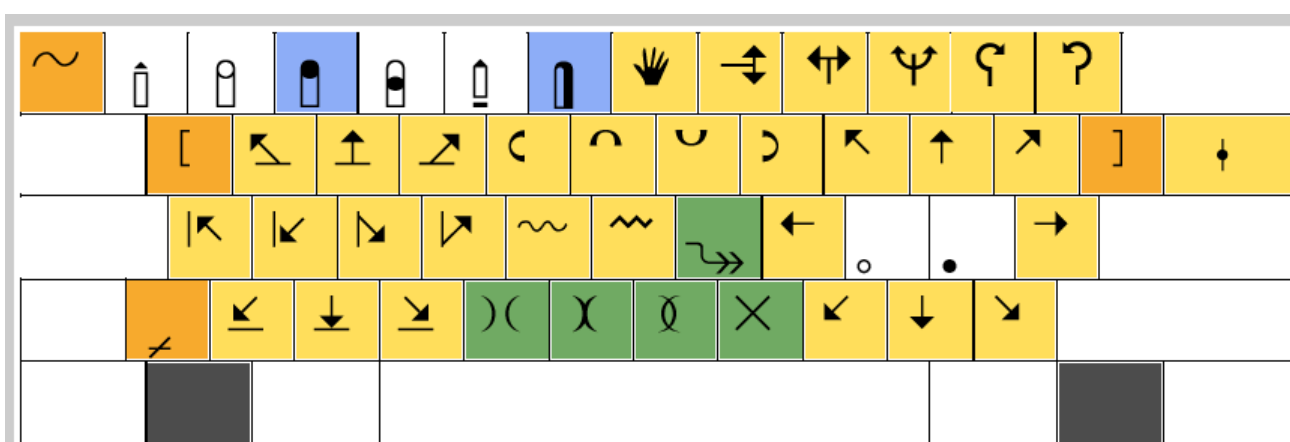
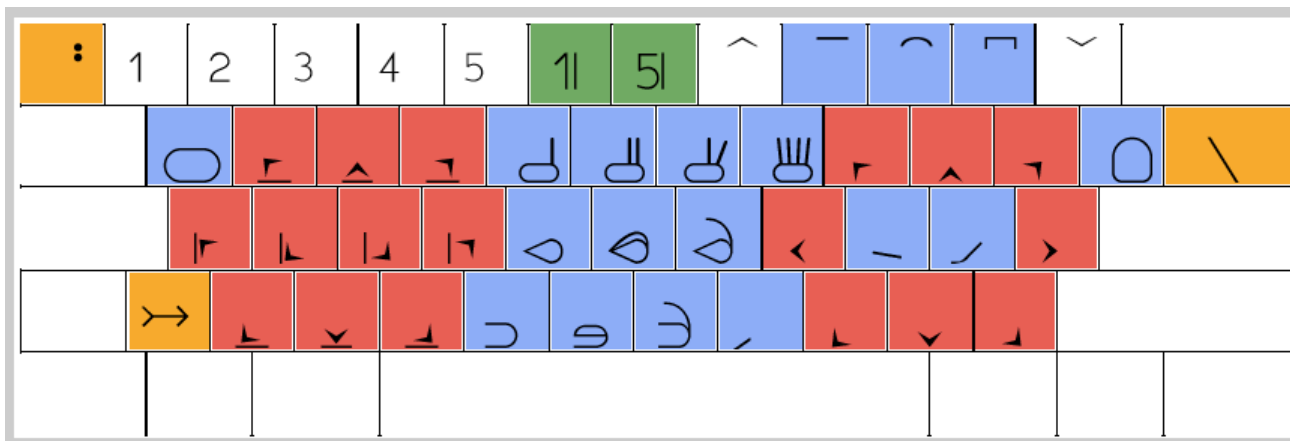

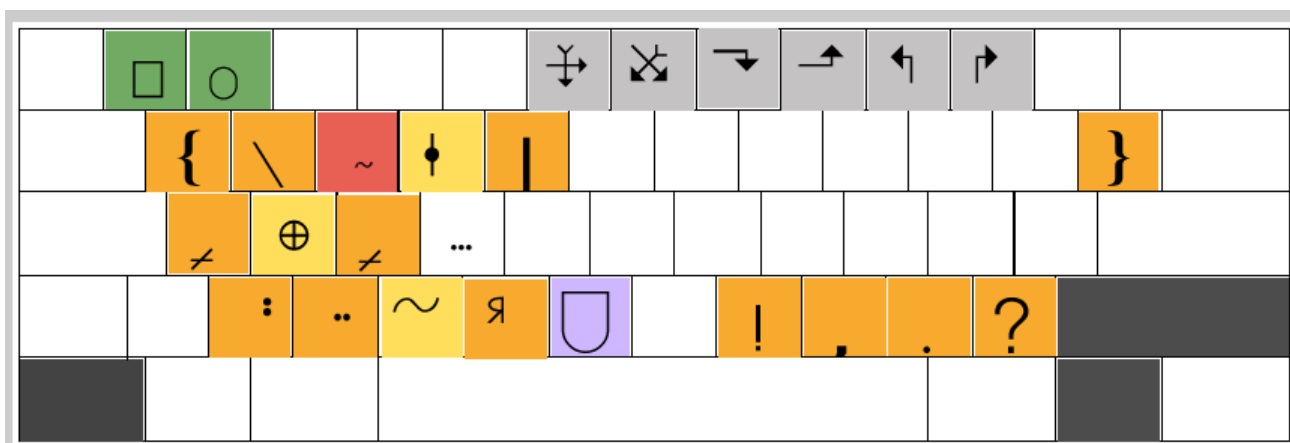
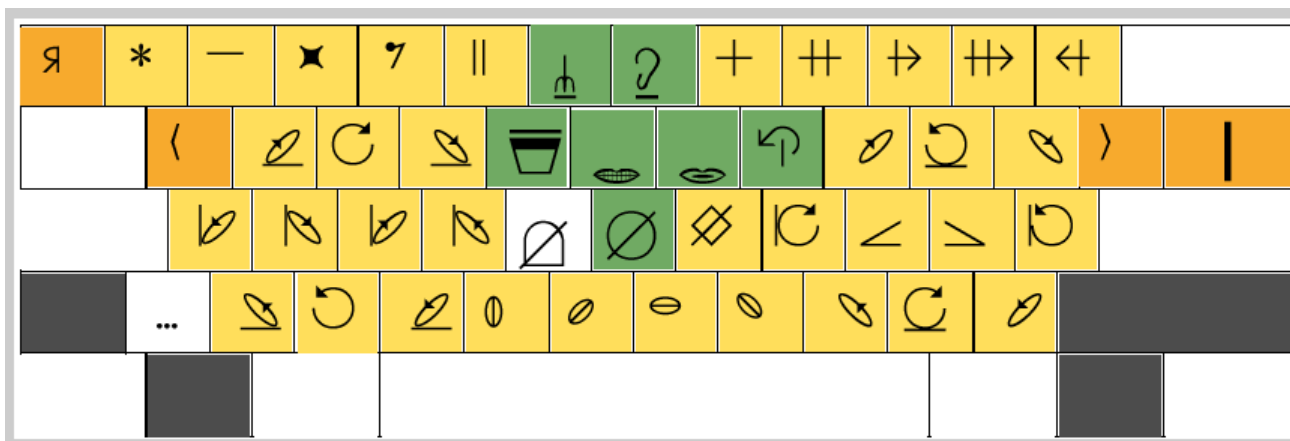

As HamNoSys strings need to be used in a grammar development environment that probably does not allow assignment of a display font for individual features, a small utility has been created that can convert back and forth between HamNoSys strings and an ASCII string consisting of the names of the HamNoSys symbols. In order to facilitate input for users not familiar with typing HamNoSys on a keyboard, an easy-to-use input method has been implemented where the user can input characters by clicking on them on a number of tabbed views.

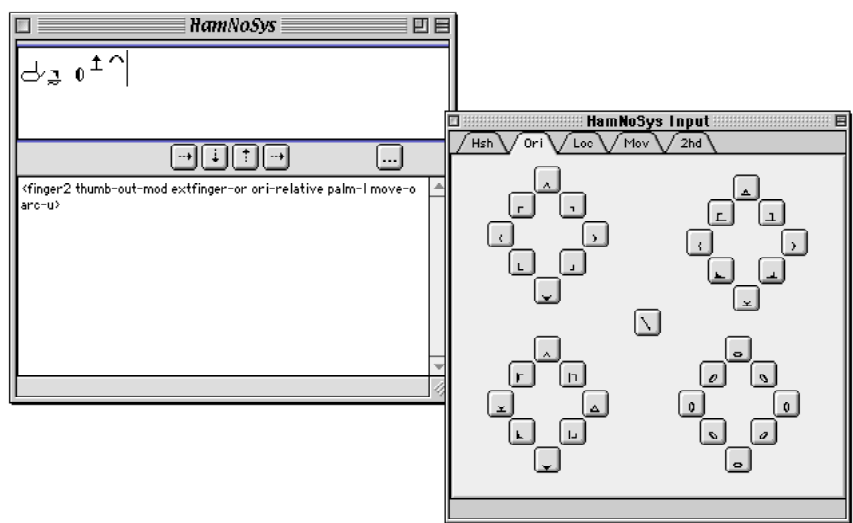

A MacOS X compatible version of HamNoSys as well as a Unicode-based implementation are planned for later in the project.⁸

*Constanze Schmaling, University of Hamburg, <mailto:constanze.schmaling@sign-lang.uni-hamburg.de>
Thomas Hanke, University of Hamburg, <mailto:thomas.hanke@sign-lang.uni-hamburg.de>
in cooperation with Susanne Bentele, Dolly Blanck, Renate Dorn, Gabriele Langer, Alexander von
Meyenn, Hortensia Popescu*

⁸ The Unicode implementation will become part of the proposal for SiGML to become a W3C standard. This is the task of Milestone 5-8 of the ViSiCAST project.

4 Encoding non-manual aspects of sign language

4.1 Introduction

In the first (1987) and second (1989) release of the HamNoSys manual, the authors indicated their intention to develop HamNoSys to also properly cover facial expressions. It was envisioned to have a placeholder for the face, with diacritic symbols to be added for mouth, eyes, cheeks etc. Mainly for technical reasons, this did not happen: With a substantial number of characters to be added to the HamNoSys font, we would have had to go beyond the 256-characters-limit of a single-byte font. Therefore, only the placeholder (□) is available. This does not mean that non-manual encoding is not possible with HamNoSys: A syntactic pattern is available to replace the hand as the standard articulator by some other body part, resulting in notations like (☞¹) (shoulder shrug). However, such forms only make sense where the event in question can be notated with HamNoSys movement operators. This is not the case, for example, with opening and closing the eyes, as opening and closing are not available as movement operators. There have been a number of suggestions how to encode such events in HamNoSys by adding some semantics to certain symbols.

While this notion could be extended by conventionalising the extra meanings or by providing missing operators, such a notation of facial expressions would not be in line with most other approaches nor with the original idea: There seem to be good reasons to notate facial expressions as sequences of states including a neutral state (not to be notated) instead of notating state change operations: It is the states, not the transitions between states, that convey the meaning. This is true even if subtle differences are only detected by a human observer when seeing the transition taking place. Moreover, states are maintained for relatively long periods of time compared to manual actions, and especially to transitions between states of facial expression. Finally, we have not found any evidence that transitions can meaningfully be modified except with respect to speed.

For other non-manual features, it is not apparent whether the dynamics themselves or states should be described. In fact, we are suggesting mixed systems here.

Most of the more recent approaches to sign language transcription prefer multi-tier representations of signed utterances to linear encodings. (cf. Bergman et al. (eds.) to appear). It does not pose a problem to transfer this approach to a feature-based grammar formalism where segments of tiers are represented as feature values. In fact, by distinguishing features contributed by the lexicon from those contributed by the grammar, this approach simplifies the unification process. We therefore suggest the following list of independent tiers in the representation of signed utterances:

- Manual activities
- Non-manual activities
 - Shoulder movements
 - Body movements
 - Head movements
 - Eye gaze
 - Facial expression
 - Eye brows
 - Eye lids
 - Nose
 - Mouthing
 - Mouth gestures
 - Mouth pictures

Obviously, in some cases the exact borderline needs to be defined:

Manual activities consist of everything involving the arms or parts thereof, i.e. not only actions where the hand or part of it is the articulator, but also those with the arm or the elbow as the primary articulator.

Facial expressions from now on refer, roughly speaking, to the upper part of the face, whereas mouthing consists of configurations of mouth/jaw, lips, tongue, cheeks, and teeth. Thereby, most grammatical facial expressions (question, conditionals, negation, utterance borders) fall into the first category, whereas lexical facial expressions mostly fall into the second. Facial expression signalling attitudes or emotions, however, cross this border, but will be neglected in this phase of the project. Mouthing can consist of mouth gestures as well as mouth pictures (mouth movements derived from spoken language words), usually these two will not co-occur in one sign.

The fact that head movement and eye gaze are not independent from each other is considered in the design of the value sets for these tiers.

The first thing to do when thinking about a coding system is to check whether already existing systems can be used, either as there are or with minor modifications. For the description of faces, a number of systems have been proposed and used in sign language research, most notably the Facial Action Coding System (FACS, Ekman & Friesen 1978), facial markers in Sutton Sign Writing (Sutton 1991), and the facial circle of the Edinburgh Non-Manual Coding System (ENCS, Colville et al. 1984).

While FACS has a well-researched basis, it requires a lot of time for learning it, too much in our context where facial encoding is only one out of many tasks for defining a lexical entry: Estimates reach from one to three months of work to be fully competent in FACS coding (Kaiser 1998). In addition, the mouth is not really within the focus of FACS. One is therefore left with the problem how to combine FACS with a detailed-enough description of mouth pictures and mouth gesture gestalt.

The facial markers in Sutton Sign Writing as well as the facial circle of ENCS give an abstracted graphical representation of the face. There is a substantial difference, however, between the two systems: While Sutton tries to be as analogue as possible, ENCS uses Stokoe notation (Stokoe 1960) operators (up, down, up and down, open, opening, narrow, narrowing, closed, closing; i.e. mixing state and dynamics description) for each of the “articulators” (eyes, nose, mouth, tongue etc.) which can also be combined.

Especially with respect to mouth gestures, ENCS seems more powerful. However, some transcription work with DGS data resulted in a number of mouthings that had no straightforward translation into ENCS. We therefore favour a system that allows adding new patterns where necessary without fundamentally changing the system.

ENCS allows an approximate transcription of mouth pictures that is more or less impossible with FACS or Sutton Sign Writing. However, a viseme-based approach⁹ for encoding mouth pictures seems to be a lot easier for transcribers who can relate the mouthing to spoken language phonemes.¹⁰

4.2 Synchronisation

The disadvantage of splitting up the information into several tiers is that basically the segment (sign) becomes the finest possible level for synchronisation. This seems to be generally acceptable.¹¹ In cases

⁹ Visemes (aka kinemes) are equivalence classes of phonemes with respect to their gestalt. Such approaches have been used in sign language research and in special education as well as in computer animation (cf. Reilly 1999, Alich 1960, Massaro 1998).

¹⁰ This is based on the assumption that sign language mouth pictures are indeed derived from spoken language. This view seems plausible at least for DGS, but even there it is not undisputed. Another approach not related to spoken language is presented by Bergman & Wallin (2000) for Swedish Sign Language.

where hystereses need to be defined, we provide coding conventions without allowing exact synchronization within signs:¹²

>	at the beginning of a non-manual code means a slight delay as compared to the manual activity
<	at the beginning of a non-manual code means that the non-manual activity starts slightly ahead of the manual activity
>	at the end of a non-manual code means that the non-manual activity lasts a bit longer than the manual activity
<	at the end of a non-manual code means that the non-manual activity ends before the end of the manual activity

If two non-manual activities have the same hysteresis code, the temporal relation between them is underspecified. If there is no manual activity in a segment, only > at the beginning and < at the end may be used to signalise that there is a transition from neutral or into neutral independent of what the neighbouring segment is.

As mouth pictures have their own timing, it is not necessary to specify the relation of the ending of the mouth picture and the manual activity: If the production of the mouth picture takes less time than the manual activity, it will simply end earlier, and the mouth will remain closed until there is another segment which contains mouthing.¹³ If it takes more time, there will be a pause in the manual activities.¹⁴

In the (expectedly rare) cases where a sequence of non-manuals belonging to one tier has to be notated for one segment, the codes are written one after the other, separated by blanks and enclosed in round brackets. In sequences of three states, a neutral state might be used that is not notated in other contexts. The zero character (0) may be used in these cases, e.g. (UL 0 UL).

If non-manuals belonging to one tier co-occur, they are bracketed by square brackets.

¹¹ Sub-sign-level synchronisation also conflicts with the use of repetition operators and such, cf. (Hanke to appear). However, it is required for “multi-syllabic” signs where non-manuals need to be synchronized to the manual activity on a syllable level, e.g. the eye gaze and head movement needs to be in sync with the manuals in a sign like LOOK-SOMEONE-UP-AND-DOWN-PL:several persons as it might occur in a narrative. This problem will be addressed when the model is extended for plural phenomena. Another counter-example is a sign contacting the puffed cheek and resulting in a release of air. One solution would be to consider this sign as a two-segment sign with the first segment consisting of the manual activity, and the second segment only consisting of the mouth gesture.

¹² We treat manual activity as the central units that impose the timing and segmentation structure on the flow of signing. The standard case is that the non-manual activities are co-temporal with the manual activities. However, there may be segments without any manual activity. The segmentation of stretches of signing without manual activity is defined by the most prominent non-manual activity tier, a switch in prominence defines a segment border as well.

¹³ However, if the next segment contains the meta-tag /HOLD/ or /SPREAD/, this behaviour is modified. Cf. chapter 4.8.3.

¹⁴ If the mouth picture shall last for exactly the same period of time as the manual activity, i.e. be slowed down or speeded up, this can be signalled by a <> at the end of the mouth picture string.

4.3 Shoulder movement

There are different kinds of shoulder movements or positions that occur in signing. Shoulder movements can be part of a sign (e.g. shoulder shrug up and down), sign-mime (hunch forward) and/or used as role shift markers (often in connection with movement of the whole torso: tilt forward/back). It has to be checked whether some of these shoulder movements only co-occur in connection with certain body movements and positions.

Shoulder movement certainly is one of the areas where we were tempted to continue to use HamNoSys characters for describing non-manual activities as they had been in use for this purpose ever since. However, plain text coding conventions for sub-sign level synchronisation and HamNoSys glyphs do not easily mix and make the use of HamNoSys more cumbersome than useful to the lexicon writer.

The inventory for shoulder activity descriptions comprises both state and dynamics descriptions. Shrugging is defined as an uncountable number of up & down movements that are perceived as a “state with motion”. For one single up & down movement, shrugging will not be used. Instead, this would be described as Ux.¹⁵

UL	left shoulder raised	(static)
UR	right shoulder raised	(static)
UB	both shoulders raised	(static)
HL	left shoulder hunched forward	(static)
HR	right shoulder hunched forward	(static)
HB	both shoulders hunched forward	(static)
SL	left shoulder shrugging (up & down)	(dynamic)
SR	right shoulder shrugging (up & down)	(dynamic)
SB	both shoulders shrugging (up & down)	(dynamic)

4.4 Body movement

Upper body movements occur mainly as markers for role shifts. Most upper body movements also include a related shoulder movement that does not need to be transcribed.

RL	rotated left	(static)
RR	rotated right	(static)

¹⁵ Shoulder tilting has been reported in the literature, e.g. (Lawson 1983), but so far could not be verified from our data. It seems to be sufficiently describable with shoulder raising. As a consequence, we have not reserved a code for this. It still needs to be researched in which cases left and right really mean ipsi- and contralateral, so it might be necessary to introduce xI and xC codes in addition to xR and xL.

TL	tilted left	(static)
TR	tilted right	(static)
TF	tilted forwards (leaning forwards)	(static)
TB	tilted backwards (leaning back)	(static)
SI	sigh (deep in- and exhalation visibly moving chest)	(dynamic)
HE	heave (chest moved upwards)	(static)
ST	straight (back upright)	(static)
RD	round (back rounded)	(static)

4.5 Head movement

Apart from nodding (up & down) and shaking (left & right), other head movements occur in signing. Sometimes the head follows the change in eye gaze, and the facing direction of the head seems to be linked to the eye gaze direction. Nodding and shaking the head requires a stable eye gaze in one direction only. It needs to be checked how closely other head movements are linked to eye gaze and vice versa. The facing direction of the head (left/right) may also be connected with shoulder or body orientation (rotated left & right) especially in marking different roles (role shift).

NO	nodding (up & down)	(dynamic)
SH	shaking (left & right)	(dynamic)
SR	turned right	(static)
SL	turned left	(static)
TR	tilted right	(static)
TL	tilted left	(static)
NF	tilted forward	(static)
NB	tilted back	(static)
PF	pushed forward	(static)
PB	pushed backward	(static)
LI	head movement linked to (dynamic) eye gaze	(dynamic)

4.6 Eye gaze

The direction of eye gaze and gaze shifts seems to have a number of different functions within signing. Some of these functions have been pointed out in the sign language literature: Certain lexical items may require a specific gaze direction, some sign constructions may require a gaze directed at the hands (some

classifier verb constructions) or other direction (e.g. in the far distance). Role shift often also involves gaze shifts. The gaze direction can be used for indexing or may be in agreement with the direction of an indexing sign. Gaze shifts and gaze direction are also most likely involved in turn taking management.

AD	towards addressee	(static)
FR	far	(static)
HD	towards the signer's own hands (handconstellation)	(static)
HI	Towards the signer's own dominant hand	(static)
HC	Towards the signer's own non-dominant hand	(static)
UP	up	(static)
DN	down	(static)
LE	left	(static)
RI	right	(static)
NO	no target, unfocussed	(static)
RO	rolling eyes	(dynamic)

4.7 Facial expression

Facial expressions occurring on the upper part of the face include movement of eyebrows, eyelids and nose. They can be part of more complex facial expressions (e.g. fear) or serve as grammatical markers (e.g. questions).

4.7.1 Eyebrows

RB	both eyebrows raised	(static)
RR	right eyebrow raised	(static)
RL	left eyebrow raised	(static)
FU	eye brows furrowed	(static)

4.7.2 Eyelids

WB	wide open eyelids	(static)
WR	wide open right eyelid	(static)

WL	wide open left eyelid	(static)
SB	narrowed, almost closed eyelids (slits)	(static)
SR	narrowed, almost closed right eyelid	(static)
SL	narrowed, almost closed left eyelid	(static)
CB	closed eyelids	(static)
CR	closed right eyelid	(static)
CL	closed left eyelid	(static)
TB	tightly shut eyelids	(static)
TR	tightly shut right eyelid	(static)
TL	tightly shut left eyelid	(static)
BB	eye blink (at the very end of a sign)	(dynamic)

Eye blinks are extremely short-timed units that usually occur at sentence boundaries, constituent boundaries and grammatical junctures within the signing stream (Baker & Padden 1978). In order to code eye blinks within a frame of longer (sign-related) time spans eye blinks which occur at sign boundaries have to be coded either as separate units (an approach that we do not take here) or one needs a coding convention which places them at the very end of the sign they are coded with (approach taken for this project).

4.7.3 Nose

WR	wrinkled nose	(static)
TW	twitching nose	(dynamic)
WI	widened nostrils	(static)

4.8 Mouthing

Mouthing consists of two subsystems, mouth gestures and mouth pictures. Mouth pictures are assumed to be derived from spoken language, here the lips and the tongue are visible articulators; movements of jaw/teeth and cheeks seem to be subordinate. Mouth gestures, on the other hand, make prominent use also of the cheeks and teeth, and the jaw is no longer restricted to up-and-down movements. In most cases, a manual sign is accompanied by either a mouth gesture or a mouth picture.

4.8.1 Mouth pictures

There is an ongoing debate about the phonological status of mouth pictures in sign languages such as DGS where most signs are accompanied by mouth pictures (cf. e.g. Ebbinghaus & Heßmann 1994 & 1995 vs.

Happ & Hohenberger 1998 vs. Keller 1999 or Boyes-Braem & Sutton-Spence 2000). Depending on the viewpoint of the reader, our suggestion to describe mouth pictures as viseme strings is more or less plausible. This by no means implies that the mouth picture of a sign is always identical to the visible part of the speech signal of the corresponding spoken language word. Abbreviations, transposition, and substitutions may occur. However, even if the (back-)translation from the mouth picture into phonemes was not be pronounceable, the mouth picture would remain describable via visemes.

There are three different approaches how to encode visemes:

- Quasi-standard orthography of the spoken language words is used, and upon performance this code is to be converted into mouth movements. In the context of our project, this would make filling the lexicon relatively straightforward, but at the same time would require the animation engine to have knowledge about the phonetics and to have a pronunciation exceptions dictionary available for the related spoken language of each target sign language. This seems to be highly undesirable since it puts computing resources load onto the client side instead of the server side.
- A phonemic transcription of the spoken language words is used. This approach splits the work between lexicon writer and animation engine. The latter, however, has a computationally cheap job to do, as it only needs to apply a homomorphism. Tools are available to translate from standard orthography into IPA-like notation so that the writer's task can be simplified as well.
- A direct viseme encoding is used, this may be a subset of an IPA-like transcription with each equivalence class represented by one class member.

Even if the third solution has been successfully tested in computer animation projects, we have decided to take the second approach as it promises to reduce the effort of revising notation should it turn out that the viseme definitions need to be revised.

For the encoding of IPA-like information by means of an alphabetic character set, there are two alternatives that could be applied in our project: SAMPA and Unicode. In the long run, Unicode supporting the well-known IPA glyphs seems to be most attractive. Currently, however, most of the tools that are available for pronunciation lookup as well as multi-lingual European databases use SAMPA (cf. Gibbon et al. 1997). Therefore, we have chosen SAMPA encoding of IPA for mouth pictures.¹⁶

SAMPA coding for a large number of languages can be found at various places on the WWW, an overview of printed reference material is contained in (Gibbon et al. 1997).

4.8.2 Mouth gestures

As it is currently not possible to present a complete set of mouth gestures that are used in each of the target languages, we use an open coding system which consists of a capital letter followed by a two-digit sequence number, optionally followed by the letter "C". To be embeddable into SAMPA-encoded mouth picture strings, these three or four characters are always enclosed by square brackets, symbols not used by SAMPA, but still in the 7-bit ASCII range.

The capital letter stands for the most prominent articulator in the mouth gesture and can take one of the following values:





D	Teeth
---	-------

¹⁶ There are subtle differences between SAMPA codes for the languages of interest so that an interpreter of the code should know for which language the code is used. It is our belief, however, that these differences do not result in visible differences in the mouth picture.







J	Jaw
L	Lips
C	Cheeks
T	Tongue





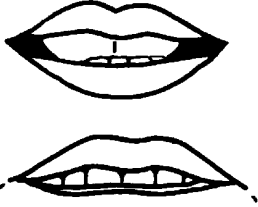
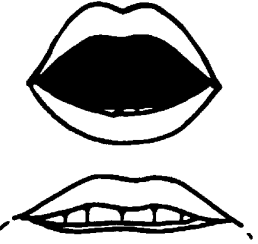
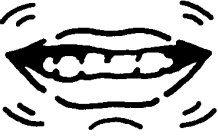



For non-symmetrical gestures, a final “C” signals that the prominent part of the gesture is not on the signer’s dominant, but on the non-dominant side.







The following table presents the current inventory:



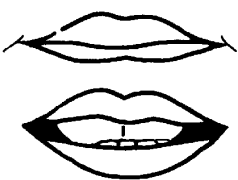

	C01	puffed cheeks
	C02	cheeks and lip area puffed
	C03	gradually puffing cheeks
	C04	one cheek puffed





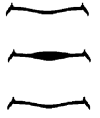
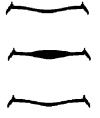

	<p>C05</p>	<p>one cheek puffed while briefly blowing out air</p>
	<p>C06</p>	<p>one cheek puffed while briefly blowing out air because cheek is pushed from outside (by finger etc.)</p>
	<p>C07</p>	<p>cheeks sucked in (without sucking in air)</p>
	<p>C08</p>	<p>cheeks sucked in, sucking in air through small opening in lips</p>
	<p>C09</p>	<p>tongue pushed visibly into cheek</p>
	<p>C10</p>	<p>tongue repeatedly pushes into cheek (visible)</p>



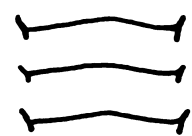

	<p>D01</p>	<p>“eee” „sss“ corners of mouth pulled tightly apart with teeth showing</p>
	<p>D02</p>	<p>„f“ upper teeth on lower lip</p>
	<p>D03</p>	<p>„ef“ slightly open mouth, moving to a position with upper teeth on lower lip</p>
	<p>D04</p>	<p>„af“ open mouth (jaws more open than in D03), moving to a position with upper teeth on lower lip</p>
	<p>D05</p>	<p>clattering teeth (lips slightly open to show teeth)</p>
	<p>D06</p>	<p>clattering teeth with raised upper lip</p>
	<p>D07</p>	<p>one „bite“ resulting in closed teeth (lips open to show teeth)</p>
	<p>J01</p>	<p>lower jaw moves sideways left and right, lips slightly forward</p>



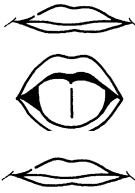

	L01	<p>„sh“</p> <p>lips puckered forward, teeth together and showing</p>
	L02	<p>„prrr“</p> <p>vibrating lips (long continuation)</p>
	L03	<p>„pr“</p> <p>vibrating lips (only brief signal)</p>
	L04	<p>pursed lips</p>
	L05	<p>„o“ („oa“), (“open o”)</p> <p>rounded, open lips, lower jaw moved downwards</p>
	L06	<p>„ooo“ (“closed o”)</p> <p>rounded, slightly open lips, lower jaw moved downwards</p>
	L07	<p>„oa“</p> <p>rounded, open lips, lower jaw open and pushed forward</p>
	L08	<p>„boam“</p> <p>3 stages: moving from closed lips (with tension) to rounded, open lips, lower jaw moved downwards to closed lips (slightly pressed together/drawn in)</p>

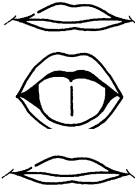
	L09	<p>„bam“</p> <p>3 stages: moving from closed lips (with tension) to open lips, lower jaw moved downwards to closed lips (slightly pressed together/drawn in)</p>
	L10	<p>„boa“</p> <p>moving from closed lips (with tension) to rounded, open lips, lower jaw moved downwards</p>
	L11	<p>„bä“</p> <p>moving from closed lips (with tension) to open lips, lower jaw moved downwards</p>
	L12	<p>„bee“</p> <p>moving from closed lips (with tension) to open, slightly spread lips, teeth slightly apart</p>
	L13	<p>„pi“</p> <p>moving from closed lips (with tension) to open, spread lips, teeth almost together</p>
	L14	<p>„pch“</p> <p>moving from closed lips (with tension) to lips puckered forward, teeth together and showing</p>
	L15	<p>„bsss“, „bee“</p> <p>moving from closed lips (with tension) to corners of mouth pulled tightly apart with teeth showing</p>

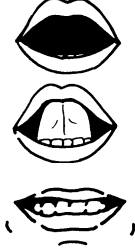
	<p>L16</p>	<p>„pf“</p> <p>2 stages:</p> <ul style="list-style-type: none"> • moving from closed lips (with tension) to • upper teeth on lower lip
	<p>L17</p>	<p>„p“</p> <p>closed lips (with tension) are briefly pushed open by a small stream of air</p>
	<p>L18</p>	<p>„p-p-p“</p> <p>L17 repeated several times</p>
	<p>L19</p>	<p>„phh“</p> <p>long blowing out air (without puffing cheeks)</p>
	<p>L20</p>	<p>„phh“</p> <p>long blowing out air (with puffing cheeks)</p>
	<p>L21</p>	<p>„ph“</p> <p>brief blowing out air (without puffing cheeks)</p>

	<p>L22</p>	<p>„ph“ brief blowing out air (with puffing cheeks)</p>
	<p>L23</p>	<p>„mmm“ lips pressed together (slightly, without breathtaking beforehand)</p>
	<p>L24</p>	<p>„mmm“ while holding breath quickly drawing breath through mouth, then holding breath with lips pressed together</p>
	<p>L25</p>	<p>„m-m-m“ slight opening and closing of jaws with lips drawn in a little and pressed together repeatedly</p>
	<p>L26</p>	<p>one side of upper lip raised</p>
	<p>T01</p>	<p>„l“ tip of tongue protruding, close to or touching upper lip</p>
	<p>T02</p>	<p>tip of tongue slightly protruding out of slightly opened lips</p>
	<p>T03</p>	<p>„l-l-l“ tip of tongue protruding, moving up and down between the lips</p>

	<p>T04</p>	<p>tongue sticks out briefly</p>
	<p>T05</p>	<p>„ä“ open mouth and jaws, tongue sticking out</p>
	<p>T06</p>	<p>tongue sticking out repeatedly</p>
	<p>T07</p>	<p>„lalala“ open mouth and jaws: tip of tongue moves inside the mouth from a position close to the upper teeth down to a neutral position repeatedly</p>
	<p>T08</p>	<p>„alalal“ (or „(a)ls(a)ls(a)ls“) 3 stages, repeated several times:</p> <ul style="list-style-type: none"> • open mouth and jaws (normal tongue position) • tongue moves upwards (and possibly a bit sideways) to upper teeth • tongue moves back down and in, jaws close a little bit more
	<p>T09</p>	<p>„als“ 3 stages:</p> <ul style="list-style-type: none"> • open mouth and jaws • tongue moves upwards (and possibly a bit sideways) to upper teeth • tongue is drawn in again, teeth close, lips slightly open

	<p>T10</p>	<p>„lf“ open mouth and jaws, tongue on upper teeth, changes to tongue in normal position, jaws more closed, upper teeth on lower lip</p>
	<p>T11</p>	<p>„laf“ 3 stages:</p> <ul style="list-style-type: none"> • open mouth and jaws, tongue on upper teeth, changes to • tongue drawn in (normal position), jaws open just a tiny bit more than before, changes to • jaws almost closed, upper teeth on lower lip
	<p>T12</p>	<p>tip of tongue touches one corner of the mouth</p>
	<p>T13</p>	<p>open mouth, tip of tongue is between lower lip and lower teeth, middle part of the tongue is showing</p>
	<p>T14</p>	<p>tip of tongue is protruded and moving sideways (left & right)</p>

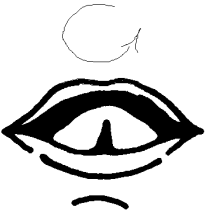
	T15	oval circling movement of tongue in open mouth
---	-----	--

This inventory covers most of the elements reported in the literature for the project target languages as well as the test data corpus that has been transcribed for the verification of this list.¹⁷ Obviously, some of the mouth gestures contained in the list could also be notated as mouth pictures. There are two reasons for “duplicating” them:

- A relation of the mouthing with a spoken language word is not obvious.
- These mouth gestures can be stretched in time to be co-temporal with the manual part of the sign.

4.8.3 Timing

Mouth pictures describe dynamics with inherent duration computed from the signer’s standard articulation speed. Mouth gestures can be static or dynamic, and in general they occupy the same time span as the manual activity they accompany. If the following period of time does not have a mouthing, the mouth returns to a neutral position (mouth closed) before the next segment starts. If, however, the next period of time is tagged with another mouthing, there is a direct transition unless the first mouthing ends early. This behaviour can be modified by two meta-symbols:

/HOLD/ ¹⁸	keeps the final state of the mouthing in the previous period of time over the whole segment
/STRETCH/	distributes the mouthing defined for the previous segment over the two segments

These meta-symbols can be repeated in subsequent segments and can be combined with the synchronisation markers < and > (cf. chapter 4.2).

*Thomas Hanke, University of Hamburg, <mailto:thomas.hanke@sign-lang.uni-hamburg.de>
 Gabriele Langer, University of Hamburg, <mailto:gabriele.langer@sign-lang.uni-hamburg.de>
 Christiane Metzger, University of Hamburg, <mailto:christiane.metzger@sign-lang.uni-hamburg.de>
 in cooperation with Constanze Schmaling*

¹⁷ If, during lexicon work or other activities, you encounter a mouth gesture not yet covered, please let us know: Please provide a description of the gesture, preferably including a drawing, a sample sign, and a movie. UH will assign a new code and update the list on the internal project website. For most of the gestures included in the list, you will find movies focusing on the mouth as well as examples of DGS signs in which they occur.

¹⁸ The slashes have been chosen to separate these multi-character symbols from other SAMPA contents.

5 Lexicon structure

5.1 Introduction

This chapter suggests how to encode the form aspects to be stored in a lexicon for signs that are not invariant. For invariant signs, the two preceding chapters describe how to encode the appearance of a sign. There are several possibilities how to extend this approach to handle inflectional¹⁹ signs:

- Every possible form of every inflectional sign has a separate entry in the lexicon (so-called full-forms-lexicon). A number of factors are contrary to this view. First, the number of inflections many verb signs can take in order to show spatial agreement is prohibitively high. Secondly, the sign located at (or oriented towards) a certain compartment of the signing space does not result in a meaningful form. It is only the association of a spatial compartment with a referent that makes such a form meaningful. Therefore, from a cognitive point of view, it seems inadequate to store full forms in the lexicon.
- For many languages, the lexicon just contains one entry per verb for “regular” verbs. The verb forms can be derived from some reference form (such as the infinitive) plus a classification: The classification determines how to manipulate the reference form to produce all desired forms. In sign languages, however, a number of factors simultaneously determine how a particular form is performed without being visible in one single reference form. Therefore, the number of entries per class would be rather low, i.e. the number of classes relatively high.

Johnston (1991a) uses a variation of this as a transcription convention: After giving a reference form, he describes the essential derivation of that form from the reference form. Obviously, this requires the reader to know the sign language, and probably also the individual sign. Therefore, in the context of automatic generation, this approach is identical to the previous one.

- The form description contained in the lexicon could be lambda expressions taking location, source, goal, classifier etc. and which result in complete HamNoSys notations, e.g.

$\lambda N. \text{ } \square \triangle \text{ } N \searrow \downarrow$

However, due to the number of obligatory and optional morphemes that can be added to a sign, the user is often confronted with incompletely resolved form descriptions that become difficult to interpret as they have to make use of a number of helper functions such as mapping from movement directions to extended finger directions.

- In a phonological framework such as those suggested by Liddell & Johnson (1989) or Sandler (1989) for ASL, some of the features that can be manipulated by adding morphemes are described individually, thereby avoiding the problems of lambda expressions which have to describe the whole form. The disadvantage would be to have two (possible four, taking into account the three target languages) separate systems that require translation and code the same kind of information in different ways.

We therefore suggest a model that is as close as possible to the HamNoSys notation any individual form will be represented in, but that also splits up information into parameters that can be expected to be shared by all target languages. Signs are assigned a type in the following type hierarchy according to the kind of inflectional they license. (Types signs can be instantiated from are shown in bold.)

¹⁹ Inflectional here shall not be restricted to verb signs as introduced by Padden (1988), but refer to any non-invariant sign with respect to location, direction, handshape or orientation. Aspect modulation, however, is currently not modelled and will probably not added along the same lines as the inflections described here.

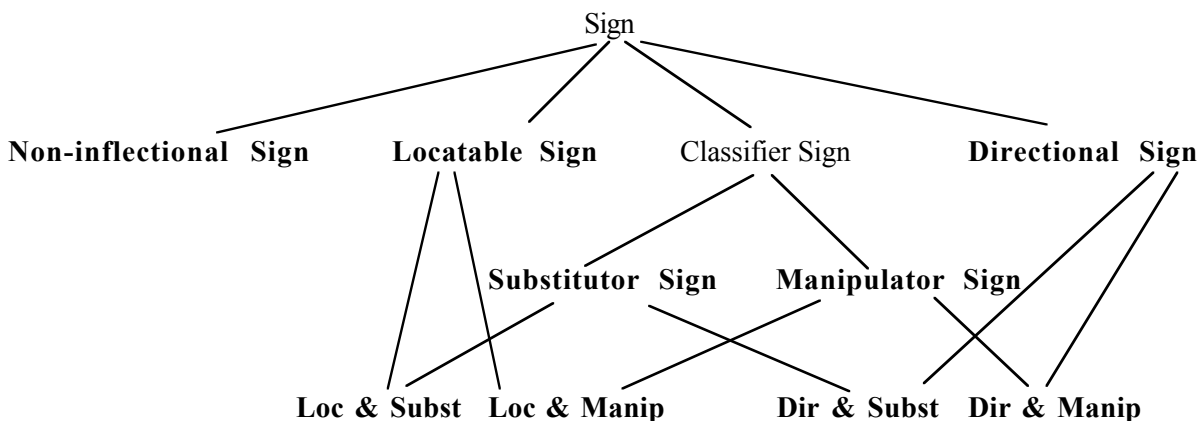

For readability reasons, the diagram does not show subtypes for locatable signs as introduced in the next paragraph. Not too surprisingly, we have not yet found any example of a substitutor sign in DGS that is neither locatable nor directional: If they such a sign exists, it probably can be considered a frozen form of some directional substitutor sign.²⁰

5.2 Locatable signs

Many signs that are normally produced in neutral space can be relocated for either obligatory or optional agreement.²¹ This kind of operation may be considered as the (non-sequential) composition of a base sign with a default location and a LOC morpheme containing the specific location. In order to make this operation easy to formulate in a constraint-based grammar as well as to make it as transparent to the user (lexicon writer) as possible, the phonetic description of the base sign is split into parameters.

Handedness	..
Handshape	□
Orientation	△↻
Handconstellation	χ
Location	
Movement	↗

The LOC morpheme contributes just the location. In a constraint-based grammar the composition is reached by unifying the two. The final HamNoSys form description can be derived by a function combining the parameter values into one string.²²

²⁰ Examples in DGS for the other types introduced are: non-inflectional: NASE (nose), locatable: ARBEITEN, (to work) locatable & substitutor: PARKEN (to park), manipulator: ESSEN (eat), locatable & manipulator: ANBRINGEN (to affix), directional: FAHREN-NACH (to go/drive to), directional & substitutor: FAHREN-cl (to move for vehicles), directional & manipulator: NEHMEN (to take).

²¹ In general, the new locations are off body as well.

²² For two-handed signs this approach obviously requires separate specification for handconstellation and location, i.e. pre-HamNoSys3.0 notations have to be converted.

This first case describes relocation of signs by transposing them in signing space while maintaining their orientation. If, however, the signer, allocates objects around him-/herself, a transposition can be described either by applying a rotation (axis is the signer) to a default location or by defining a specific location – as in the first case – plus a rotation. In order to keep the two cases as parallel as possible, we suggest the second way, i.e. the LOC in this case not only defines a location, but also a rotation. The rotation feature in the LOC morpheme can take any of the values with \circ meaning 0° rotation. However, only the rotations $\circ \circ \circ \circ$ are likely to occur. The rotation adds a bit of complexity to the mapping function from feature sets to linear HamNoSys notations as rotation does not necessarily provide a direct mapping for all orientations.

A number of locatable signs are restricted to body surfaces. This requires a third subtype of the LOC morpheme, as these signs need to be oriented on the body surface. A prototypical example of this case is OPERIEREN (operate) in DGS where orientation is determined by doctors’ standard practice how to cut the body when starting the operation. Once again, the mapping function can handle the conversion into standard HamNoSys strings.

For OPERIEREN, some signers also use a form of this sign in neutral space, possibly operating on a virtual surface. If it can be confirmed that this occurrence really is the same sign, a hierarchy of LOC morphemes could be introduced to handle that case:

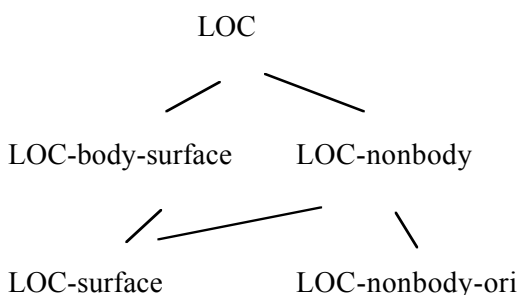

5.3 Directional signs

While locatable signs make reference to one location in signing space, directional signs are defined to refer to two locations. Usually, they feature a path movement from the source location to the target location, but as a minimum they have an orientation from source to goal.

Once again, in order to model these signs in a way that is easy to formulate and understand for the lexicon writer, we use a model incorporating SRC (source) and GOL (goal) morphemes of identical structure.²³ The fully instantiated nested feature structure for the phonetic contents of a sign is transferred into linear HamNoSys by means of the mapping function.

SRC and GOL themselves have three features, POR (Point of Reference), HEIGHT, and DIST (distance). The point of reference is to be unified with two-dimensional projection of a location in signing space,

²³ Features of the lexicon entries, but outside the phonetic description, determine how SRC and GOL map onto syntactic and semantic functions such as subject or agens and theme. This means that the information whether a verb sign is a so-called backwards verb (Meir 1995) is not considered to be part of the form description itself.

with HEIGHT specifying the third dimension.²⁴ DIST with values contact, close, and dironly (direction only) determines how far the path approaches the source or goal.²⁵ If both SRC and GOL specify a DIST value of dironly, the sign is oriented from SRC to GOL with only a very short movement or even without an actual path movement, e.g. the DGS sign SMS-VERSENDEN (to send a mobile phone short message). Unless a MOD feature is defined (with HamNoSys values for arc-shaped movements), the path is a straight line. By specifying a SEC feature, secondary movements (described by HamNoSys symbols) can be added as well.

Several person reference systems have been suggested in the literature. Here we follow Meier (1990) with slight modifications:

The points of reference are defined from context. One special point of reference always defined is first-person, identical in position with the signer. Among the non-first-person references, one may be considered as second person (signer's addressee), usually directly opposite to the signer.

As we do not assume the existence of an underspecified 0-person²⁶ spatially identical to first-person, directional signs always starting at the signer's body are modelled to only take GOL morphemes, with SRC filled out by the lexicon. Likewise, signs can be modelled to have GOL filled out by the lexicon, and to take only SRC arguments.

Obviously, not all signs can take any combination of SRC and GOL instantiations. In fact, we believe that in DGS the points of reference for SRC and GOL cannot coincide. Furthermore, many verb signs are restricted to first-to-non-first and vice versa, not allowing non-first-non-first assignments. As these restrictions do not affect the phonetic description, they will be covered in the description of the grammar model.²⁷

Example: In a first approach, FRAGEN (ask s.o.) can be modelled with SRC [DIR: i, HEIGHT: chin, DIST: close] and GOL [DIR: j, HEIGHT: breast level, DIST: dironly].

For many directional signs not only movement, but also orientation (extended finger direction and/or palm orientation) depends on SRC and GOL. If the extended finger direction is relative to the movement direction, most often it is either parallel or orthogonal to that. The extended finger direction is notated with standard HamNoSys symbols for the case that the movement direction is \pm followed by the HamNoSys subscript for relative orientation. Directions for other movements can be derived automatically by rotation. The same rule applies for the palm orientation.

Example BESUCHEN (to visit): EFD \approx , PLM \circ As the movement is specified to be an arc towards top, the initial extended finger direction is slightly above horizon for BESUCHEN-src:1-gol:2.

²⁴ If the context provides specific dimensions or location information for the reference object/person, HEIGHT is to be considered relative to this information. By this, verbs like FRAGEN (ask) can be modelled to look different when addressing a child and not a peer or when addressing a person behind the window on first floor. Note that the three-subfeatures-model for source and goal is a significant simplification as it implies that persons as well as objects have a fixed orientation in the world. As a consequence, FRAGEN directed to a person lying on the ground cannot be modelled correctly. Furthermore, person reference when applied to animals as in children's stories remains anthropomorphic, i.e. the head has to be the topmost part of the animal which might not be true for dragons and other creatures.

²⁵ Obviously, contact or close to a point of reference that is not first-person do not mean physical contact, but full extent of the movement to reach the point.

²⁶ The advantage of assuming a 0-person is a plausible explanation for possible differences in pro-drop behaviour for directional signs starting or ending at the signer's body. However, so far no such signs could be identified for DGS.

²⁷ ViSiCAST Deliverable D5-3, scheduled for July 2001.

For a couple of signs found in DGS, the extended finger direction only partially depends on the path movement from source to goal: The direction projected onto a horizontal plane is defined by the movement whereas the vertical part of the direction is fixed. This can be notated by specifying two directions: From the first, DIR, only the projection onto the horizontal plane is evaluated, from the second, VRT, only the vertical component is evaluated.

Example: HASSEN (to hate): EFD-DIR ↗ , EFD-VRT ↑ , PLM 0 The sign starts with an extended finger direction towards GOL, but 45° above horizon.

If required, the movement description may contain specification of final orientation.

A feature FOB (flip on backwards) determines how orientation information can be derived from the relative orientation values specified in the feature structure for those combinations of SRC and GOL that are not directed away from the signer: If FOB is true, the extended finger direction is reversed if the path is towards the signer.²⁸ The palm orientation is flipped independently of the FOB feature if the extended finger direction is towards the body as HamNoSys palm orientation is relative to the body, not the wrist.

5.4 Classifier signs

We consider a sign that inherits some form aspects from the semantics of one of its arguments as a classifier sign, the information inherited is called classifier.²⁹ In most cases, the classifier consists of a handshape specification, but may also define orientation (either absolutely or as a default) as well as handedness. In the sign, the information to be inherited needs to be explicitly specified (as an agreement feature). Different subtypes of classifiers such as cl-manip or cl-subst (manipulator classifiers and substitutor classifiers, for a definition see Johnston & Schembri 1996 or Arbeitsgruppe Fachgebärdenlexika 1998) may inherit from different features of one reference object.

As classifier signs often are directional signs as well, orientation defined in the classifier may be underspecified to be unified with orientation information from the SRC-GOL pair.

Example: The signs for the three-signs-sentence

ICH KAFFEEBECHER-loc:a-agr:cl_manip:5cm-cylindrical-object-upright NEHMEN-src:a-gol:1-cl_manip:5cm-cylindrical-object-upright

(I MUG-loc:a-agr:cl_manip:5cm-cylindrical-object-upright TAKE-src:a-gol:1-cl_manip:5cm-cylindrical-object-upright)

may be notated in an HPSG-like feature structure as follows (heavily abbreviated):

ICH

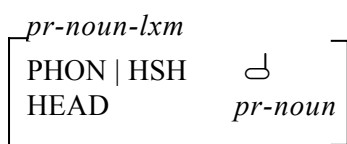

²⁸ DGS examples with FOB=true are GEBEN (give) and FRAGEN (ask). BESUCHEN (visit) has FOB=false. For combinations that result in a path neither towards nor away from the signer, the flipping takes place if the path is towards the contralateral side.

²⁹ There is no widely accepted definition in sign linguistics what exactly a classifier sign is. However, the working definition given here should be consistent to a certain degree with most approaches.

KAFFEEBECHER

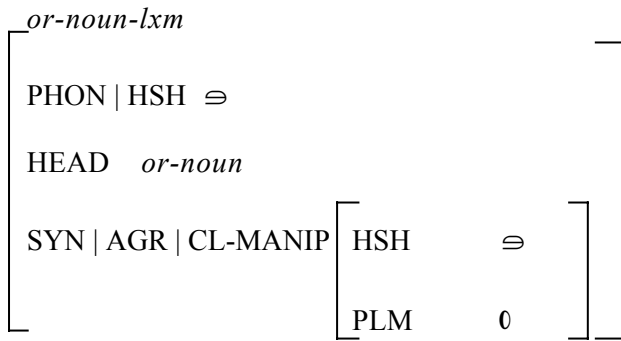

NEHMEN

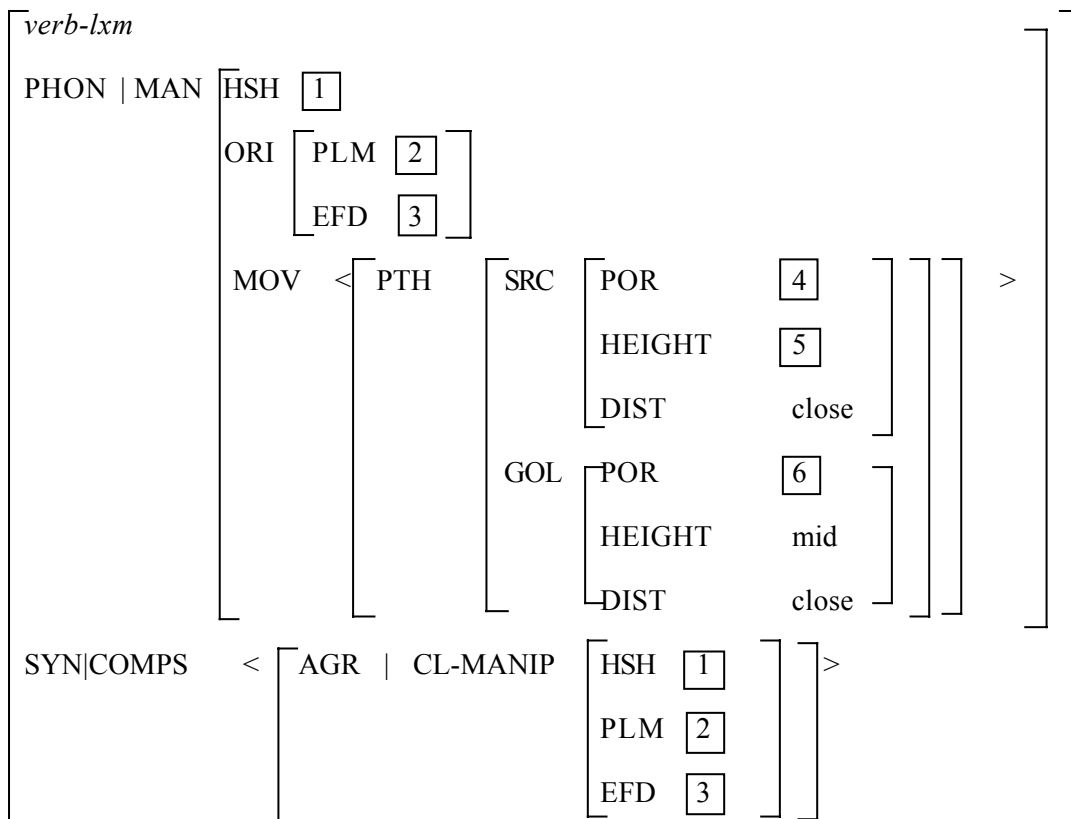

5.5 Future work

The approach suggested here needs to prove powerful enough in the actual lexicon and grammar development. As directional verbs are limited to straight or curved paths from source to goal, one obvious shortcoming is the handling of plural forms for these verbs.³⁰

Johnston (1991b:38) mentions a small class of signs in AUSLAN that – while to be considered as directional signs in the classification suggested so far – start at a fixed body location even if the source is non-first person, e.g. SHOW. To our knowledge, no such form exists for DGS, and it remains to be seen whether they occur in the other target languages. The surface form suggests that this phenomenon can be handled in parallel with plural forms although ad-hoc solutions should be easy to implement if needed.

Co-articulation is another sign language specific construction that requires post-lexical modification of the sign form, e.g. to switch hands. The lexicon, however, should license some of these modifications, such as weak-drop.³¹

Constructions with directional verbs the body will make a general shortcoming of the current approach visible: Currently, both classifiers as well as form descriptions within lexical items specify whole handshapes. However, anatomical ease of articulation in directional signs clearly shows that often only some parts of the hand are invariant, e.g. the fingers. The whole handshape description is then a function of fingers and orientation, not the other way round. To cope with this problem, the notation needs to be generalised to allow parts of the hands to become the articulator of a sign, orientation information would then be for the articulator, not for the metacarpals as in the current system.

*Thomas Hanke, University of Hamburg, <mailto:thomas.hanke@sign-lang.uni-hamburg.de>
in cooperation with Sung-Eun Hong, Gabriele Langer, Christiane Metzger, Hortensia Popescu,
Constanze Schmaling*

³⁰ Plural verbs will only be handled in the second phase of grammar development, to be described in Deliverable D5-4.

³¹ As the proper handling of co-articulation phenomena requires a more sophisticated co-temporality model than that presented in this document, its implementation will only start once the Deliverable 5-2 that will provide the required model is available.

References

- Alich, G.: Zur Erkennbarkeit von Sprachgestalten beim Ablesen vom Munde. Bonn, Dissertation (1960).
- Arbeitsgruppe Fachgebärdenlexika: *Fachgebärdenlexikon Tischler / Schreiner*. 2 vols. Hamburg : Signum (1998).
- Baker, C. and C. Padden: Focusing on the Nonmanual Components of American Sign Language. 25-57. In: Siple, P. (ed.): *Understanding Language through Sign Language Research*. New York: Academic (1978).
- Bergman, B. and L. Wallin: A Preliminary Analysis of Mouth Segments in Swedish Sign Language In: Boyes Braem, P. and R. Sutton-Spence (eds.): *The Hands are the Head of the Mouth: The Mouth as Articulator in Sign Languages*. Hamburg: Signum (2000).
- Bergman, B. et al. (eds.): Intersign Sign Language Databases, Transcription and Tagging Tools, special issue of *Sign Language and Linguistics*, to appear.
- Boyes Braem, P. and R. Sutton-Spence (eds.): *The Hands are the Head of the Mouth: The Mouth as Articulator in Sign Languages*. Hamburg: Signum (2000).
- Colville, M. et al: Edinburgh Non-manual Coding System. (ENCS), Working paper I. Edinburgh BSL Research Project. Moray House College (1984). Unpublished manuscript.
- Ebbinghaus, H. and J. Heßmann: Formen und Funktionen von Ablesewörtern in gebärdensprachlichen Äußerungen (Teil I). In: *Das Zeichen. Zeitschrift für Sprache und Kultur Gehörloser*. 30 8 (1994) - 480-487.
- Ebbinghaus, H. and J. Heßmann: Formen und Funktionen von Ablesewörtern in gebärdensprachlichen Äußerungen (Teil II). In: *Das Zeichen. Zeitschrift für Sprache und Kultur Gehörloser*. 31 9 (1995) - S. 50-61
- Ekman, P. and W. Friesen: *Facial action coding system: A technique for the measurement of facial movement: Investigator's guide 2 parts*. Palo Alto : Consulting Psychologists Pr. (1978).
- Fröhlich, M. and I. Wachsmuth: Gesture recognition of the upper limbs: from signal to symbol. In: Wachsmuth, I. and M. Fröhlich (eds.): *Gesture and sign language in human computer interaction: proceedings International Gesture Workshop, Bielefeld, Germany, Sept. 17–19, 1997*. Berlin: Springer (1998). 173–184.
- Gibbon, D. et al. (eds): *Handbook of Standards and Resources for Spoken Language Systems*. Berlin: de Gruyter (1997).
- Hanke, T.: HamNoSys; Notation von Gebärdensprache. HamNoSys. URL <http://www.sign-lang.uni-hamburg.de/HamNoSys> (2000, October).
- Hanke, T.: Sign Language Transcription with syncWRITER. To appear in *Sign Language and Linguistics*.
- Happ, D. and A. Hohenberger: Gebärdensprache und Mundbild - Eine Entgegnung auf Ebbinghaus. In: *Das Zeichen. Zeitschrift für Sprache und Kultur Gehörloser*. 44 12 (1998) - 262-267.

Hofmann, F.G. and G. Hommel: Analyzing human gestural motions using acceleration sensors. In: Harling, P.A. and A.D.N. Edwards (eds.): *Progress in gestural interaction: proceedings of Gesture Workshop '96*. Berlin: Springer (1997). 39–59.

Johnston, T.: Transcription and glossing of sign language texts: Examples from AUSLAN (Australian Sign Language). In: *International Journal of Sign Linguistics*. 1 2 (1991) - 3-28.

Johnston, T.: Spatial syntax and spatial semantics in the inflection of signs for the marking of person and location in AUSLAN. In: *International Journal of Sign Linguistics*. 1 2 (1991) - 29-62.

Johnston, T. and A. Schembri: Defining and profiling lexis in sign language - Auslan. Poster presented at the Fifth International Conference on Theoretical Issues in Sign Language Research. September 19-22, 1996 Montréal. (1996).

Kamp, H. and U. Reyle: *From Discourse to Logic*. Vols 1 & 2. Dordrecht: Kluwer (1993).

Kaiser, S.: Coding facial expressions with FACS: Current applications in emotion research and possible use for studying "Mouthing" and "Mouth Gestures" in sign language. Paper presented at the 2nd Intersign Workshop Leiden, December 1998.

Keller, J.: Mundbilder in europäischen Gebärdensprachen. In: *Das Zeichen. Zeitschrift für Sprache und Kultur Gehörloser*. 47 13 (1999) - 136-143

Lawson, L.: Multi-channel signs in British Sign Language. In: Kyle, J. and B. Woll (eds): *Language in sign: An international perspective on sign language. (Proceedings of the Second International Symposium of Sign Language Research in Bristol, U.K. in July 1981)*. London: Croom Helm (1983). 97-105.

Liddell, S. and R. Johnson: American Sign Language: The phonological base. (Originally prepared in 1985). In: *Sign Language Studies*. 64 18 (1989) - 195-277.

Massaro, D.: *Perceiving talking faces: from speech perception to a behavioral principle*. Cambridge MA: MIT Pr. (1998).

Meier, Richard P.: Person deixis in American Sign Language. In: Fischer, Susan D. / Siple, Patricia (eds): *Theoretical issues in Sign Language Research. Vol. 1.: Linguistics*. Chicago, London: Univ. of Chicago Pr. (1990) - 175-190.

Meir, I.: Explaining backwards verbs in ISL: Syntactic-semantic interaction. In: Bos, H. and G. Schermer (eds): *Sign Language Research 1994: Proceedings of the Fourth European Congress on Sign Language Research, Munich, September 1-3, 1994*. Hamburg : Signum (1995).

Miller, C.: Some reflections on the need for a common sign notation. To appear in *Sign Language and Linguistics*.

Padden, C.: Grammatical theory and signed languages. In: Newmeyer, F. (ed): *Linguistics: The Cambridge survey. Vol.2: Linguistic theory: extensions and implications*. Cambridge : Cambridge Univ. Pr. (1988) - 250-266.

Prillwitz, S. et al.: *HamNoSys. Hamburg Notation System for Sign Language. An introduction*. Hamburg : Zentrum für deutsche Gebärdensprache (1987).

Prillwitz, S. et al: *HamNoSys. Version 2.0; Hamburg Notation System for Sign Languages. An introductory guide*. Hamburg : Signum (1989).

Reilly, J.: Looking at Faces: The acquisition of non-manual morphology in ASL. Paper presented at the 4th Intersign Workshop London (1999).

Safar, E. and I. Marshall: Translation of English Text to a DRS-based, Sign Language Oriented Semantic Representation, submitted to ACL conference 2001.

Sandler, W.: *Phonological representation of the sign : linearity and nonlinearity in American Sign Language*. Dordrecht : Foris Publications (1989).

Stokoe, W.: *Sign language structure: An outline of the visual communication systems of the American deaf*. Buffalo, NY : Univ. of Buffalo (1960).

Sutton, V.: *Lessons in Sign Writing. Textbook*. La Jolla, CA : Center for Sutton Movement Writing (1991).

Sutton, V.: SignWriting: On the occasion of its 25th anniversary November 1999. In: *Sign Language and Linguistics*. 2 2 (1999) - 271-281.

van Eijck, J. and H. Kamp: Representing Discourse In Context. In: van Benthem, J. and A. ter Meulen: *Handbook of Logic and Language*, Amsterdam: Elsevier (1997). 179-238.